



## Pumps

- Submersible Sewage Pump
- Submersible Dewatering Pump
- Submersible Slurry Pump



**Applications**

- Drainage of wastewater from the attenuation tank, purifying tank and sewage tank in water treatment plant
- Drainage of waste water containing fibrous additives from leather factory and food processing factory.
- Sewage management, accumulated water, septic tank, stock farm.
- Pumping sewage form hotels, restaurants, schools and public buildings

**Pump**

- High-efficiency & anti-clogging enclosed channel impeller
- Flexible installations with hoses, pipes or quick-coupling systems
- Float switch as standard accessory for single phase (≤1.1kW)
- Double-end mechanical seal
- Stainless steel welded shaft
- Liquid temperature: 0 - 40 °C
- Liquid PH value: 4 - 10
- Max. immersion depth: 5 m

**Motor**

- Frequency/Pole number: 50 Hz/2
- Insulation class: F
- Protection class: IPX8
- Bearing: Ball type

**Identification Codes**

**50 SWE m 8 - 16 - 1.1 L**

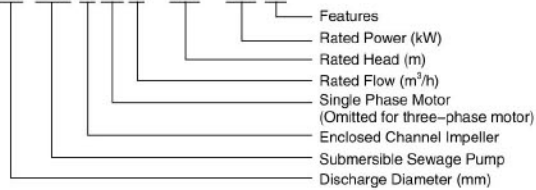

**Technical Data**

Model		Discharge mm (inch)	Power		Rated Flow (m³/h)	Max. Flow (m³/h)	Rated Head (m)	Max. Head (m)	Max. Solid Dia (mm)
Single Phase	Three Phase		kW	HP					
50SWE6-12-0.55L	50SWE6-12-0.55L	50 (2")	0.55	0.75	6	19	12	15	20
50SWE6-16-0.75L	50SWE6-16-0.75L	50 (2")	0.75	1	6	22	16	19	20
50SWE10-10-0.75L	50SWE10-10-0.75L	50 (2")	0.75	1	10	20	10	15	20
50SWE8-16-1.1L	50SWE8-16-1.1L	50 (2")	1.1	1.5	8	26	16	19	15
50SWE8-20-1.5L	50SWE8-20-1.5L	50 (2")	1.5	2	8	25	20	22	15
50SWE15-20-2.2L	50SWE15-20-2.2L	50 (2")	2.2	3	15	45	20	23	25
-	50SWE15-25-3L	50 (2")	3	4	15	51	25	27	25

**Dimension**

Model		L1	L2	L3	L4	H		H1	D	D1	D2	M
Single Phase	Three Phase					1-	3-					
50SWE6-12-0.55L	50SWE6-12-0.55L	212	184	96	120	461	461	65	45	110	14	14
50SWE6-16-0.75L	50SWE6-16-0.75L					479	479					
50SWE10-10-0.75L	50SWE10-10-0.75L					570	529					
50SWE8-16-1.1L	50SWE8-16-1.1L	223	191	135	150	571	530	70	50	110	14	16
50SWE8-20-1.5L	50SWE8-20-1.5L					571	530					
50SWE15-20-2.2L	50SWE15-20-2.2L	268	221	112	163	571	530	70	50	110	14	16
-	50SWE15-25-3L					571	530					

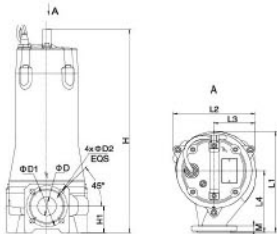

**Hydraulic Performance Curves**

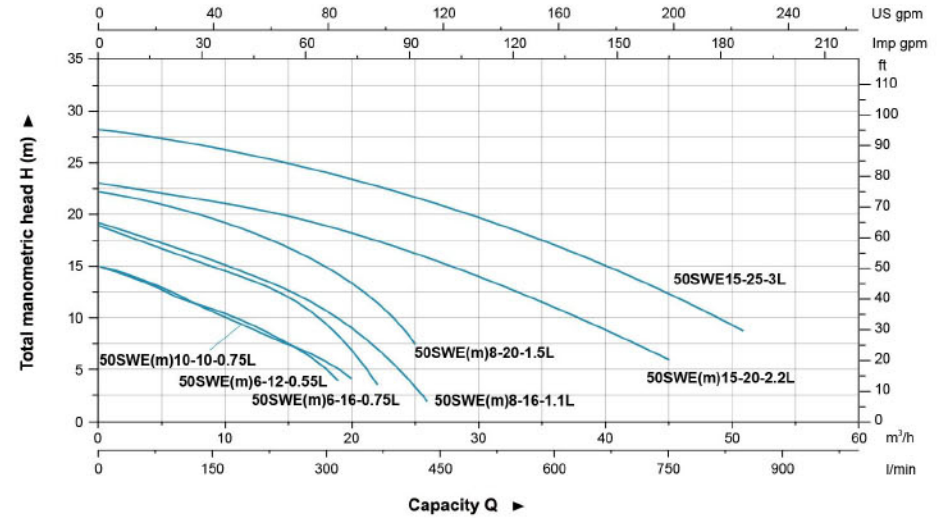

**Materials Table**

No.	Part	Material
1	Handle	ZG46
2	Upper cover	HT200
3	Upper bearing seat	HT200
4	Motor body	HT200
5	Oil chamber	HT200
6	Pump cover	HT200
7	Pump body	HT200
8	Impeller	HT200
9	Oil seal	
10	Mechanical seal	Upper Si/Carbon Lower Si/Sic
11	Bearing	
12	Rotor	
13	Stator	

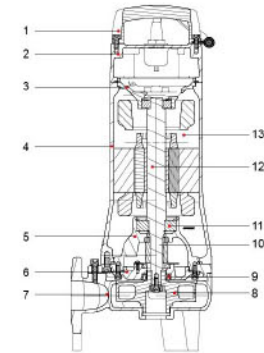

**Package Information**

Model		GW (kg)		L (mm)	W (mm)	H (mm)	Quantity (PCS/20 TEU)
Single Phase	Three Phase	1-	3-				
50SWE6-12-0.55L	50SWE6-12-0.55L	24.7	24	746	254	286	544
50SWE6-16-0.75L	50SWE6-16-0.75L	26	25.3	746	254	286	544
50SWE10-10-0.75L	50SWE10-10-0.75L	25.8	25	746	254	286	544
50SWE8-16-1.1L	50SWE8-16-1.1L	33.6	31.7	749	289	368	354
50SWE8-20-1.5L	50SWE8-20-1.5L	43.2	38.4	924	284	363	294
50SWE15-20-2.2L	50SWE15-20-2.2L	44.9	46.3	924	284	363	294
-	50SWE15-25-3L	-	49.5	874	284	363	316



**Applications**

- Drainage of wastewater from the attenuation tank, purifying tank and sewage tank in water treatment plant
- Drainage of waste water containing fibrous additives from leather factory and food processing factory.
- Sewage management, accumulated water, septic tank, stock farm.
- Pumping sewage form hotels, restaurants, schools and public buildings

**Pump**

- High-efficiency & anti-clogging enclosed channel impeller
- Flexible installations with hoses, pipes or quick-coupling systems
- Float switch as standard accessory for single phase (≤1.1kw)
- Double-end mechanical seal
- Stainless steel welded shaft
- Liquid temperature: 0 - 40 °C
- Liquid PH value: 4 - 10
- Max. immersion depth: 5 m

**Motor**

- Frequency/Pole number: 50 Hz/2
- Insulation class: F
- Protection class: IPX8
- Bearing: Ball type

**Identification Codes**

**65 SW E m 15 - 10 - 1.1 L**

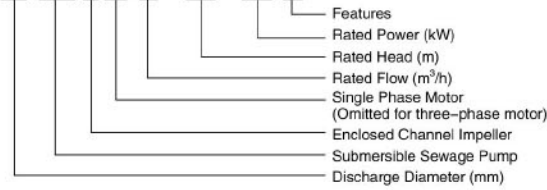

**Technical Data**

Model		Discharge mm (inch)	Power		Rated Flow (m³/h)	Max. Flow (m³/h)	Rated Head (m)	Max. Head (m)	Max. Solid Dia (mm)
Single Phase	Three Phase		kW	HP					
65SWE m 15-10-1.1L	65SWE15-10-1.1L	65 (2.5")	1.1	1.5	15	34	10	14	25
65SWE m 15-15-1.5L	65SWE15-15-1.5L	65 (2.5")	1.5	2	15	44	15	20	25
-	65SWE25-17-2.2L	65 (2.5")	2.2	3	25	40	17	24	25
-	65SWE25-22-3L	65 (2.5")	3	4	25	45	22	28.5	25
-	65SWE25-28-4L	65 (2.5")	4	5.5	25	50	28	31.5	25

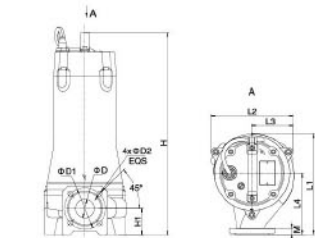

**Dimension**

Model		L1	L2	L3	L4	H		H1	D	D1	D2	M
Single Phase	Three Phase					1~	3~					
65SWE m 15-10-1.1L	65SWE15-10-1.1L	288				490	490					
65SWE m 15-15-1.5L	65SWE15-15-1.5L					581	540					
-	65SWE25-17-2.2L	289	225	117	178	-	540	77.5	65	130	14	16
-	65SWE25-22-3L					-	571					
-	65SWE25-28-4L					-	571					

**Hydraulic Performance Curves**

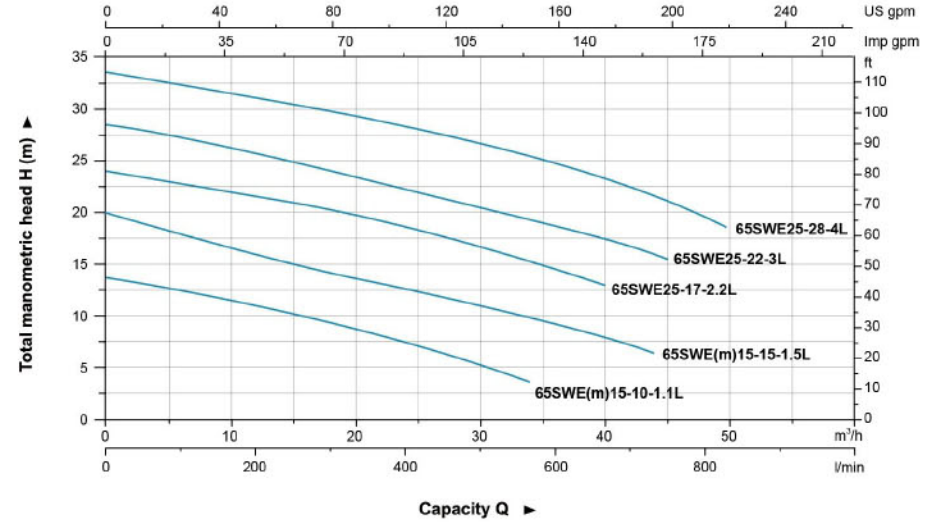

**Materials Table**

No.	Part	Material
1	Handle	ZG45
2	Upper cover	HT200
3	Upper bearing seat	HT200
4	Motor body	HT200
5	Oil chamber	HT200
6	Pump cover	HT200
7	Pump body	HT200
8	Impeller	HT200
9	Oil seal	HT200
10	Mechanical seal	Upper: Silicon Carbide Lower: SUS316
11	Bearing	
12	Rotor	
13	Stator	

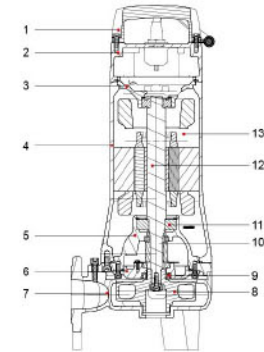

**Package Information**

Model		GW (kg)		L (mm)	W (mm)	H (mm)	Quantity (PCS/20'TEU)
Single Phase	Three Phase	1~	3~				
65SWE m 15-10-1.1L	65SWE15-10-1.1L	37.9	35.8	749	289	368	354
65SWE m 15-15-1.5L	65SWE15-15-1.5L	45.7	41.9	924	284	363	294
-	65SWE25-17-2.2L	-	44.1	924	284	363	294
-	65SWE25-22-3L	-	52	874	284	363	316
-	65SWE25-28-4L	-	55.1	874	284	363	316



Impeller

( Hose coupling as standard.  
Flange elbow is available on request. )



### Applications

- Drainage of wastewater from the attenuation tank, purifying tank and sewage tank in water treatment plant
- Drainage of waste water containing fibrous additives from leather factory and food processing factory.
- Sewage management, accumulated water, septic tank, stock farm.
- Pumping sewage form hotels, restaurants, schools and public buildings

### Pump

- High-efficiency & anti-clogging enclosed channel impeller
- Flexible installations with hoses, pipes or quick-coupling systems
- Double-end mechanical seal
- Stainless steel welded shaft
- Liquid temperature: 0 - 40 °C
- Liquid PH value: 4 - 10
- Max. immersion depth: 5 m

### Motor

- Frequency/Pole number: 50 Hz/2
- Insulation class: F
- Protection class: IPX8
- Bearing: Ball type

### Identification Codes

**80 SW E 40 - 9 - 2.2 L**

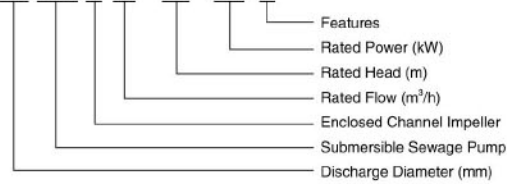

### Technical Data

Model	Discharge mm (inch)	Power		Rated Flow (m³/h)	Max. Flow (m³/h)	Rated Head (m)	Max. Head (m)	Max. Solid Dia (mm)
		kW	HP					
80SWE40-9-2.2L	80(3")	2.2	3	40	69.5	9	17	30
80SWE40-13-3L	80(3")	3	4	40	76	13	21	30
80SWE40-18-4L	80(3")	4	5.5	40	83	18	23	30

### Dimension

Model	L1	L2	L3	L4	H	H1	D	D1	D2	M
80SWE40-9-2.2L										
80SWE40-13-3L	265	223	112	160	557	86	80	150	18	16
80SWE40-18-4L										

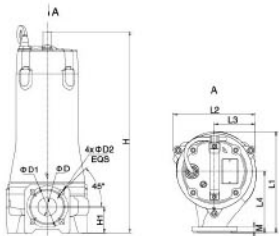

### Hydraulic Performance Curves

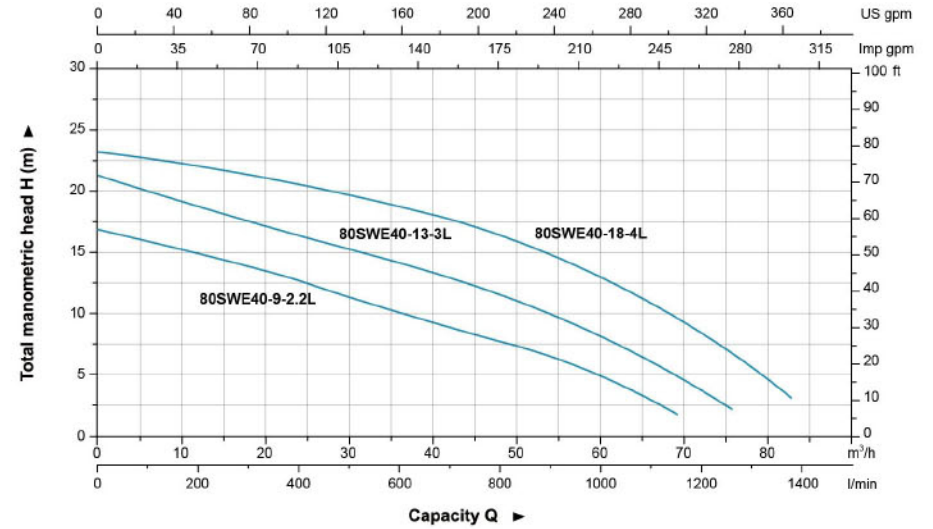

### Materials Table

No.	Part	Material
1	Handle	ZG45
2	Upper cover	HT200
3	Upper bearing seat	HT200
4	Motor body	HT200
5	Oil chamber	HT200
6	Pump cover	HT200
7	Pump body	HT200
8	Impeller	HT200
9	Oil seal	
10	Mechanical seal	Upper:SiC/Garter Lower:SiC/SiC
11	Bearing	
12	Rotor	
13	Stator	

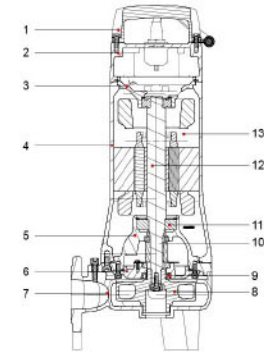

### Package Information

Model	GW (kg)	L (mm)	W (mm)	H (mm)	Quantity (PCS/20'FEU)
80SWE40-9-2.2L	46.4	924	284	363	294
80SWE40-13-3L	53.8	874	284	363	316
80SWE40-18-4L	56.3	874	284	363	316



### Applications

- Drainage of wastewater from the attenuation tank, purifying tank and sewage tank in water treatment plant
- Drainage of waste water containing fibrous additives from leather factory and food processing factory.
- Sewage management, accumulated water, septic tank, stock farm.
- Pumping sewage form hotels, restaurants, schools and public buildings

### Pump

- Semi-open vortex impeller, suitable for liquid containing impurities and long fiber substance
- Flexible installations with hoses, pipes or quick-coupling systems
- Float switch as standard accessory for single phase (≤1.1kw)
- Double-end mechanical seal
- Stainless steel welded shaft
- Liquid temperature: 0 - 40 °C
- Liquid PH value: 4 - 10
- Max. immersion depth: 5 m

### Motor

- Frequency/Pole number: 50 Hz/2
- Insulation class: F
- Protection class: IPX8
- Bearing: Ball type

### Identification Codes

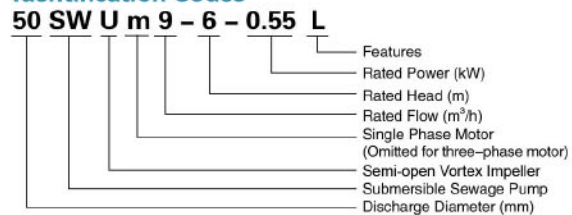

### Technical Data

Model		Discharge mm (inch)	Power		Rated Flow (m³/h)	Max. Flow (m³/h)	Rated Head (m)	Max. Head (m)	Max. Solid Dia (mm)
Single Phase	Three Phase		kW	HP					
50SWUm9-6-0.55L	50SWU9-6-0.55L	50 (2")	0.55	0.75	9	19	6	9.5	35
50SWUm13.2-4-0.55L	50SWU13.2-4-0.55L	50 (2")	0.55	0.75	13	22	4	6	50
50SWUm12-8-0.75L	50SWU12-8-0.75L	50 (2")	0.75	1	12	22.5	8	13	35
50SWUm15-5.5-0.75L	50SWU15-5.5-0.75L	50 (2")	0.75	1	15	27	5.5	9	50

### Dimension

Model		L1	L2	L3	L4	H	H1	D	D1	D2	M
Single Phase	Three Phase										
50SWUm9-6-0.55L	50SWU9-6-0.55L	195	160	80	121	483	64	35	110	14	14
50SWUm13.2-4-0.55L	50SWU13.2-4-0.55L	201	166	86							
50SWUm12-8-0.75L	50SWU12-8-0.75L	195	160	80							
50SWUm15-5.5-0.75L	50SWU15-5.5-0.75L	201	166	86							

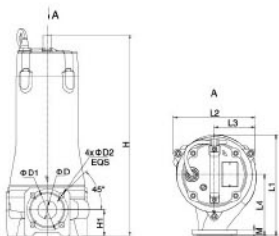

### Hydraulic Performance Curves

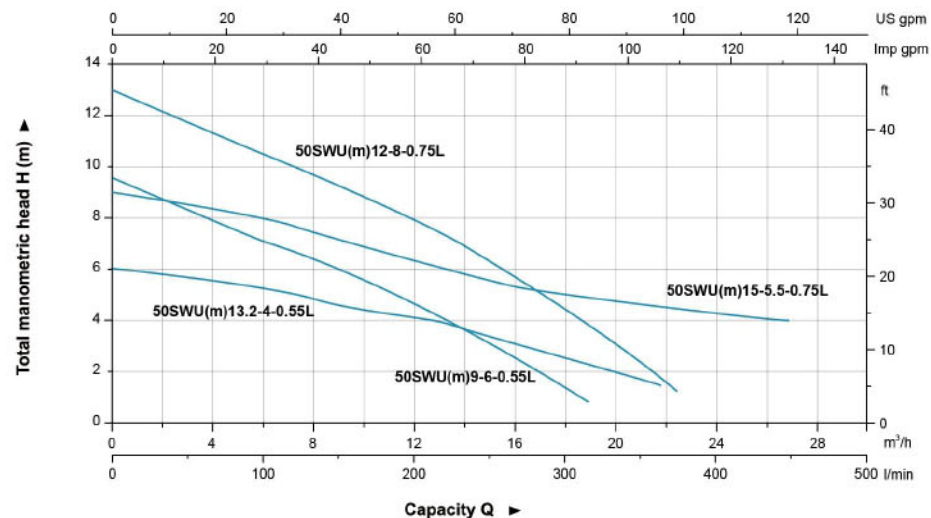

### Materials Table

No.	Part	Material
1	Handle	ZG45
2	Upper cover	HT200
3	Upper bearing seat	HT200
4	Motor body	HT200
5	Oil chamber	HT200
6	Pump cover	HT200
7	Pump body	HT200
8	Impeller	HT200
9	Oil seal	HT200
10	Mechanical seal	Upper Silicon Carbide Lower Sic/SiC
11	Bearing	
12	Rotor	
13	Stator	

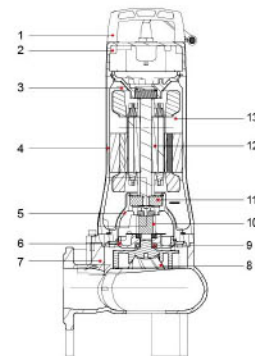

### Package Information

Model		GW (kg)		L (mm)	W (mm)	H (mm)	Quantity (PCS/20'TEU)
Single Phase	Three Phase	1~	3~				
50SWUm9-6-0.55L	50SWU9-6-0.55L	24.6	23.9	746	254	286	544
50SWUm13.2-4-0.55L	50SWU13.2-4-0.55L	25.1	24.3	746	254	286	544
50SWUm12-8-0.75L	50SWU12-8-0.75L	25.9	25.2	746	254	286	544
50SWUm15-5.5-0.75L	50SWU15-5.5-0.75L	26.4	25.6	746	254	286	544

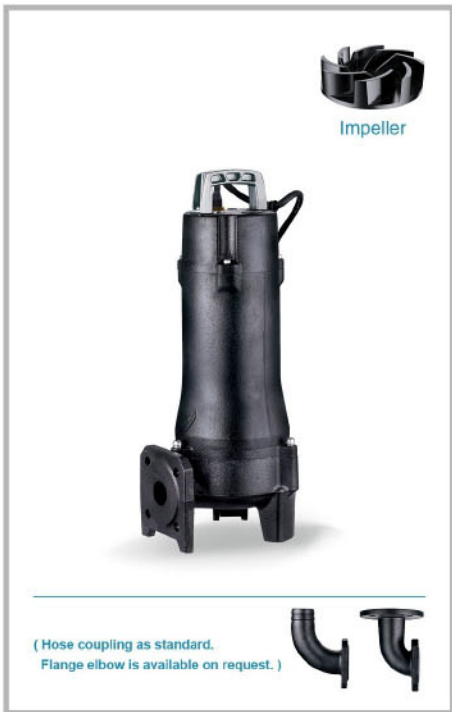

Impeller

(Hose coupling as standard.  
Flange elbow is available on request.)



### Applications

- Drainage of wastewater from the attenuation tank, purifying tank and sewage tank in water treatment plant
- Drainage of waste water containing fibrous additives from leather factory and food processing factory.
- Sewage management, accumulated water, septic tank, stock farm.
- Pumping sewage from hotels, restaurants, schools and public buildings

### Pump

- Semi-open vortex impeller, suitable for liquid containing impurities and long fiber substance
- Flexible installations with hoses, pipes or quick-coupling systems
- Double-end mechanical seal
- Stainless steel welded shaft
- Liquid temperature: 0 - 40 °C
- Liquid PH value: 4 - 10
- Max. immersion depth: 5 m

### Motor

- Frequency/Pole number: 50 Hz/2
- Insulation class: F
- Protection class: IPX8
- Bearing: Ball type

### Identification Codes

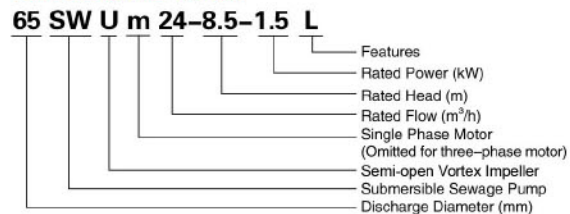

### Technical Data

Model		Discharge mm (inch)	Power		Rated Flow (m³/h)	Max. Flow (m³/h)	Rated Head (m)	Max. Head (m)	Max. Solid Dia (mm)
Single Phase	Three Phase		kW	HP					
65SWUm24-8.5-1.5L	65SWU24-8.5-1.5L	65 (2.5")	1.5	2	24	38	8.5	13	55
65SWUm24-12.5-2.2L	65SWU24-12.5-2.2L	65 (2.5")	2.2	3	24	40	12.5	17	55
-	65SWU30-11-3L	65 (2.5")	3	4	30	46	11	18	55
-	65SWU30-16-4L	65 (2.5")	4	5.5	30	54	16	24	55

### Dimension

Model		L1	L2	L3	L4	H		H1	D	D1	D2	M
Single Phase	Three Phase					1~	3~					
65SWUm24-8.5-1.5L	65SWU24-8.5-1.5L					631	590					
65SWUm24-12.5-2.2L	65SWU24-12.5-2.2L	266	218	110	167	631	590	91	65	130	14	16
-	65SWU30-11-3L					-	621					
-	65SWU30-16-4L											

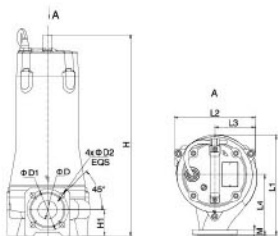

### Hydraulic Performance Curves

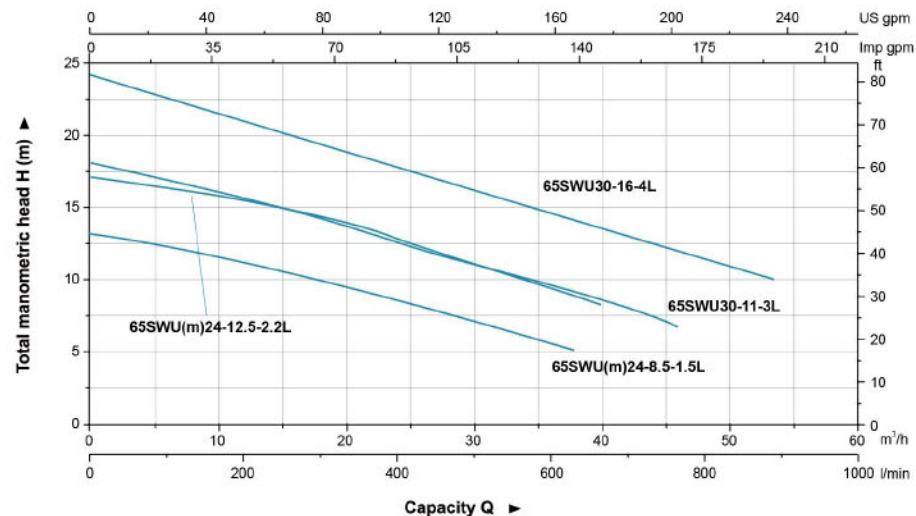

### Materials Table

No.	Part	Material
1	Handle	ZG45
2	Upper cover	HT200
3	Upper bearing seat	HT200
4	Motor body	HT200
5	Oil chamber	HT200
6	Pump cover	HT200
7	Pump body	HT200
8	Impeller	HT200
9	Oil seal	
10	Mechanical seal	Upper:Silicon Carbide Lower:SiC/SiC
11	Bearing	
12	Rotor	
13	Stator	

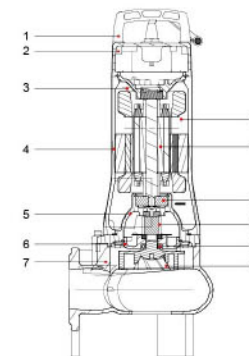

### Package Information

Model		GW (kg)		L (mm)	W (mm)	H (mm)	Quantity (PCS/20 TEU)
Single Phase	Three Phase	1~	3~				
65SWUm24-8.5-1.5L	65SWU24-8.5-1.5L	48.8	45	924	284	363	294
65SWUm24-12.5-2.2L	65SWU24-12.5-2.2L	49	47.2	924	284	363	294
-	65SWU30-11-3L	-	54.5	874	284	363	316
-	65SWU30-16-4L	-	56.7	874	284	363	316

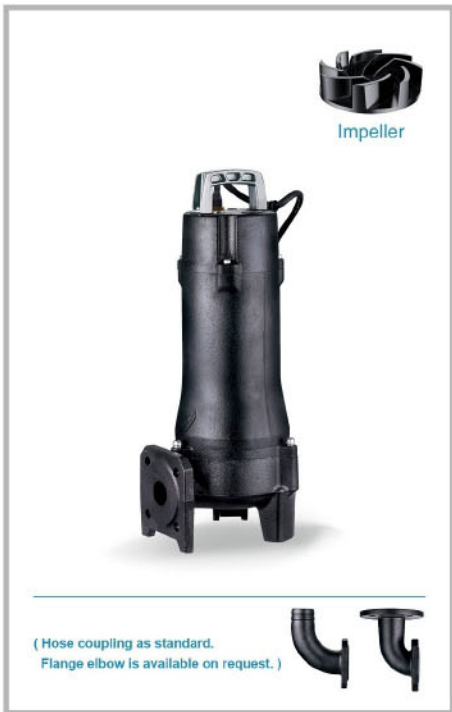

Impeller

**Applications**

- Drainage of wastewater from the attenuation tank, purifying tank and sewage tank in water treatment plant
- Drainage of waste water containing fibrous additives from leather factory and food processing factory.
- Sewage management, accumulated water, septic tank, stock farm.
- Pumping sewage form hotels, restaurants, schools and public buildings

**Pump**

- Semi-open vortex impeller, suitable for liquid containing impurities and long fiber substance
- Flexible installations with hoses, pipes or quick-coupling systems
- Double-end mechanical seal
- Stainless steel welded shaft
- Liquid temperature: 0 - 40 °C
- Liquid PH value: 4 - 10
- Max. immersion depth: 5 m

**Motor**

- Frequency/Pole number: 50 Hz/2
- Insulation class: F
- Protection class: IPX8
- Bearing: Ball type

**Identification Codes**

**80 SW U m 30 - 4.5 - 1.5 L**

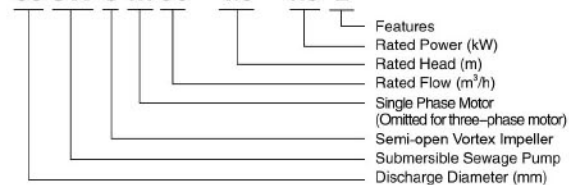

( Hose coupling as standard.  
Flange elbow is available on request. )



**Technical Data**

Model		Discharge mm (inch)	Power		Rated Flow (m³/h)	Max. Flow (m³/h)	Rated Head (m)	Max. Head (m)	Max. Solid Dia (mm)
Single Phase	Three Phase		kW	HP					
80SWUm30-4.5-1.5L	80SWU30-4.5-1.5L	80(3")	1.5	2	30	50	4.5	6	76
80SWUm30-7-2.2L	80SWU30-7-2.2L	80(3")	2.2	3	30	45	7	8	76

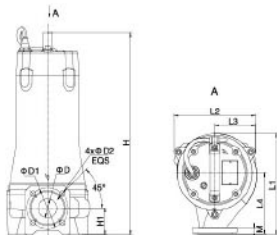

**Dimension**

Model		L1	L2	L3	L4	H		H1	D	D1	D2	M
Single Phase	Three Phase					1~	3~					
80SWUm30-4.5-1.5L	80SWU30-4.5-1.5L	260	224	118	149	672	631	122	75	150	18	18
80SWUm30-7-2.2L	80SWU30-7-2.2L											

**Hydraulic Performance Curves**

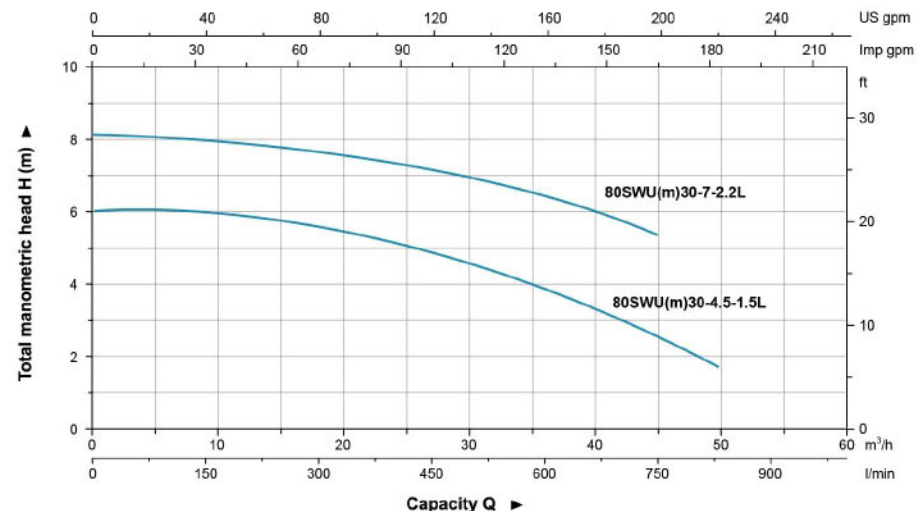

**Materials Table**

No.	Part	Material
1	Handle	ZG45
2	Upper cover	HT200
3	Upper bearing seat	HT200
4	Motor body	HT200
5	Oil chamber	HT200
6	Pump cover	HT200
7	Pump body	HT200
8	Impeller	HT200
9	Oil seal	
10	Mechanical seal	Upper: SiC/Carbon Lower: SiC/SiC
11	Bearing	
12	Rotor	
13	Stator	

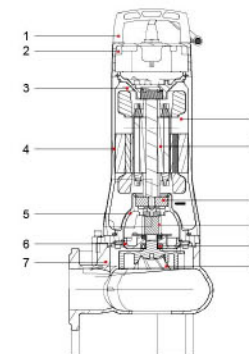

**Package Information**

Model		GW (kg)		L (mm)	W (mm)	H (mm)	Quantity (PCS/20 TEU)
Single Phase	Three Phase	1~	3~				
80SWUm30-4.5-1.5L	80SWU30-4.5-1.5L	49.1	45.4	924	284	363	294
80SWUm30-7-2.2L	80SWU30-7-2.2L	49.4	47.5	924	284	363	294



### Applications

- Used In pressure sewage system
- Drainage of wastewater from individual residences, apartment buildings, recreational developments, hotels
- Transferring wastewater of commercial buildings, industrial plants, wastewater sampling, small hospitals
- Schools, federal, state and local parks, wastewater drainage
- To transfer various wastewater and sewage

### Pump

- Semi-open vortex impeller & reliable grinding system
- Flexible installations with hoses, pipes or quick-coupling systems
- Float switch as standard accessory for single phase (≤1.1kw)
- Double-end mechanical seal
- Stainless steel welded shaft
- Liquid temperature: 0 - 40 °C
- Liquid PH value: 4 - 10
- Max. immersion depth: 5 m

### Motor

- Frequency/Pole number: 50 Hz/2
- Insulation class: F
- Protection class: IPX8
- Bearing: Ball type

### Identification Codes

**32 SW P m 3.6 - 17 - 1.1 L / QG**

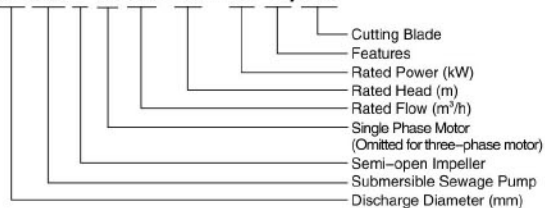

### Technical Data

Model		Discharge mm (inch)	Power		Rated Flow (m³/h)	Max. Flow (m³/h)	Rated Head (m)	Max. Head (m)	Max. Solid Dia (mm)
Single Phase	Three Phase		kW	HP					
32SWPm3.6-17-1.1L/QG	32SWP3.6-17-1.1L/QG	32(1¼")	1.1	1.5	3.6	8	17	18	-
32SWPm3.6-23-1.5L/QG	32SWP3.6-23-1.5L/QG	32(1¼")	1.5	2	3.6	10	23	23.2	-
32SWPm3.6-30-2.2L/QG	32SWP3.6-30-2.2L/QG	32(1¼")	2.2	3	3.6	12	30	30.2	-

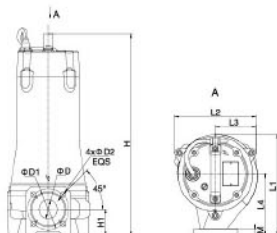

### Dimension

Model		L1	L2	L3	L4	H		H1	D	D1	D2	M
Single Phase	Three Phase					1~	3~					
32SWPm3.6-17-1.1L/QG	32SWP3.6-17-1.1L/QG	230	191	96	140	473	473	73	32	90	14	16
32SWPm3.6-23-1.5L/QG	32SWP3.6-23-1.5L/QG					564	523					
32SWPm3.6-30-2.2L/QG	32SWP3.6-30-2.2L/QG					564	523					

### Hydraulic Performance Curves

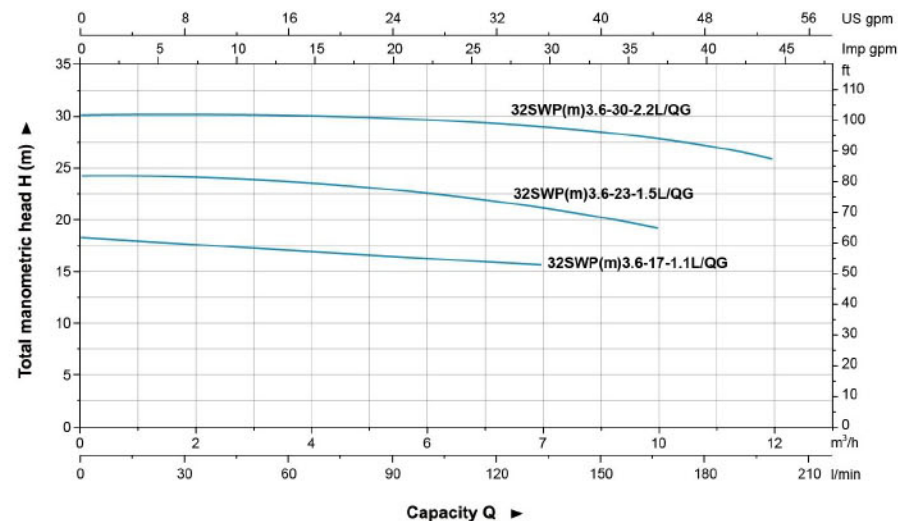

### Materials Table

No.	Part	Material
1	Handle	ZG45
2	Upper cover	HT200
3	Upper bearing seat	HT200
4	Motor body	HT200
5	Oil chamber	HT200
6	Pump cover	HT200
7	Pump body	HT200
8	Impeller	HT200
9	Cutting ring	108Cr17
10	Radial cutter	108Cr17
11	Oil seal	
12	Mechanical seal	Upper:SiC/Carbon Lower:302St
13	Bearing	
14	Rotor	
15	Stator	

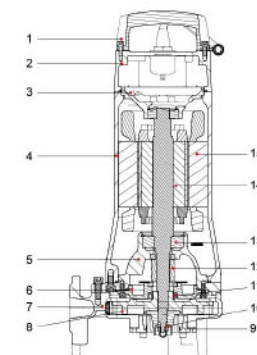

### Package Information

Model		GW (kg)		L (mm)	W (mm)	H (mm)	Quantity (PCS/20' TEU)
Single Phase	Three Phase	1~	3~				
32SWPm3.6-17-1.1L/QG	32SWP3.6-17-1.1L/QG	34	32.1	749	289	366	354
32SWPm3.6-23-1.5L/QG	32SWP3.6-23-1.5L/QG	41.5	38.4	924	284	363	294
32SWPm3.6-30-2.2L/QG	32SWP3.6-30-2.2L/QG	41.1	41.6	924	284	363	294



**Applications**

- Used In pressure sewage system
- Drainage of wastewater from individual residences, apartment buildings, recreational developments, hotels
- Transferring wastewater of commercial buildings, industrial plants, wastewater sampling, small hospitals
- Schools, federal, state and local parks, wastewater drainage
- To transfer various wastewater and sewage

**Pump**

- Semi-open vortex impeller & reliable grinding system
- Flexible installations with hoses, pipes or quick-coupling systems
- Double-end mechanical seal
- Stainless steel welded shaft
- Liquid temperature: 0 - 40 °C
- Liquid PH value: 4 - 10
- Max. immersion depth: 5 m

**Motor**

- Frequency/Pole number: 50 Hz/2
- Insulation class: F
- Protection class: IPX8
- Bearing: Ball type

**Identification Codes**

**50 SW P 12 - 19 - 2.2 L /QG**

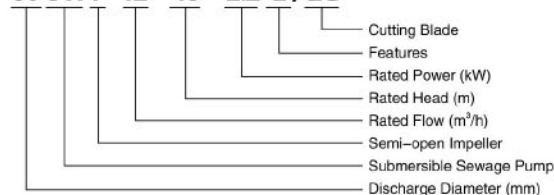

**Technical Data**

Model	Discharge mm (inch)	Power		Rated Flow (m³/h)	Max. Flow (m³/h)	Rated Head (m)	Max. Head (m)	Max. Solid Dia (mm)
		kW	HP					
50SWP10-10-1.1L/QG	50 (2")	1.1	1.5	10	20.5	10	17.5	-
50SWP12-15-1.5L/QG	50 (2")	1.5	2	12	21.5	15	19.5	-
50SWP12-19-2.2L/QG	50 (2")	2.2	3	12	24.5	19	23	-
50SWP12-22-3L/QG	50 (2")	3	4	12	26	22	25.5	-
50SWP12-30-4L/QG	50 (2")	4	5.5	12	26.5	30	33	-

**Dimension**

Model	L1	L2	L3	L4	H	H1	D	D1	D2	M
50SWP10-10-1.1L/QG	245.5	217	109	145	472.5	73	40	100	14	16
50SWP12-15-1.5L/QG					523					
50SWP12-19-2.2L/QG	246	217	109	145	554	73	40	100	14	16
50SWP12-22-3L/QG										
50SWP12-30-4L/QG										

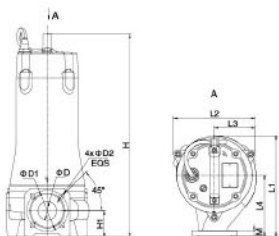

**Hydraulic Performance Curves**

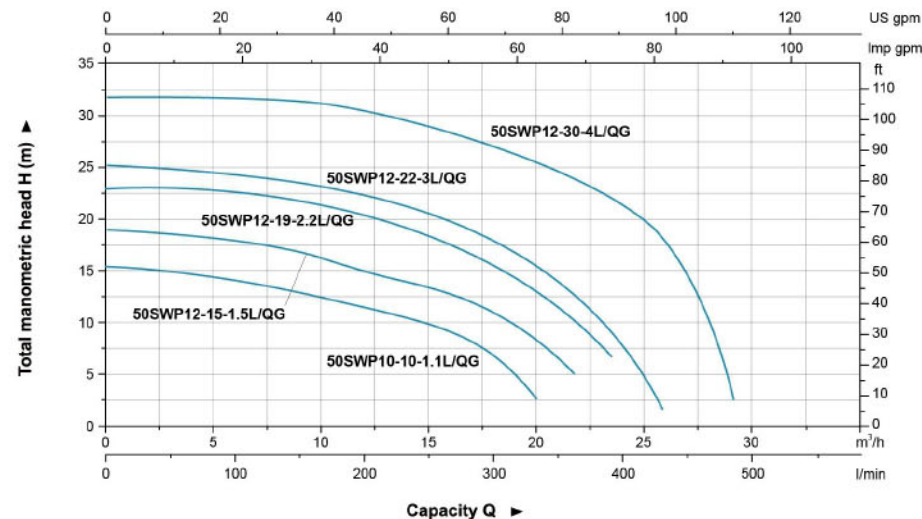

**Materials Table**

No.	Part	Material
1	Handle	ZG45
2	Upper cover	HT200
3	Upper bearing seat	HT200
4	Motor body	HT200
5	Oil chamber	HT200
6	Pump cover	HT200
7	Pump body	HT200
8	Impeller	HT200
9	Cutting ring	108Cr17
10	Radial cutter	108Cr17
11	Oil seal	
12	Mechanical seal	Upper:SiC/Carbon Lower:St3Cr16
13	Bearing	
14	Rotor	
15	Stator	

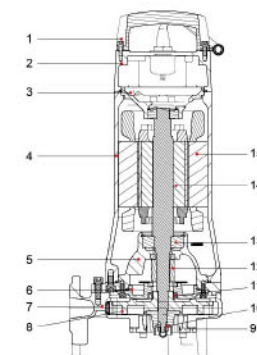

**Package Information**

Model	GW (kg)	L (mm)	W (mm)	H (mm)	Quantity (PCS/20' TEU)
50SWP10-10-1.1L/QG	39.7	749	289	368	354
50SWP12-15-1.5L/QG	46.8	924	284	363	294
50SWP12-19-2.2L/QG	45.2	924	284	363	294
50SWP12-22-3L/QG	51.5	874	284	363	316
50SWP12-30-4L/QG	53.9	874	284	363	316



**Applications**

- Used In pressure sewage system
- Drainage of wastewater from individual residences, apartment buildings, recreational developments, models
- Transferring wastewater of commercial buildings, industrial plants, wastewater sampling, small hospitals
- Schools, federal, state and local parks, wastewater drainage
- To transfer various wastewater and sewage

**Pump**

- Flexible installations with hoses, pipes or quick-coupling systems
- Double-end mechanical seal
- Stainless Steel welded shaft
- Liquid density  $\leq 1.2 \times 10^3 \text{ kg/m}^3$
- Liquid temperature: 0 - 40 °C
- Liquid PH value: 4 - 10
- Max. immersion Depth: 5 m

**Motor**

- Copper winding
- Insulation class: F
- Protection class: IPX8
- Voltage: 380V/50Hz 3-phase

**Identification Codes**

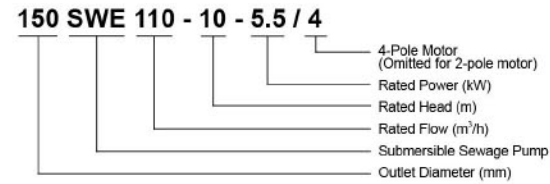

**Technical Data**

Model	Motor Power		Speed r.p.m	Max. Flow m <sup>3</sup> /h	Max. Head m	Discharge mm (inch)	Guide Rial Fitting	Max. Solid Dia mm	G.W kg	Packing Dimension mm
	kW	HP								
150SWE150-10-7.5/4	7.5	10	1450	300	16	150 (6")	150-150	75	160	1154x549x532
150SWE110-10-5.5/4	5.5	7.5	1450	260	12	150 (6")	150-150	75	155	1154x549x532
150SWE100-10-7.5	7.5	10	2900	150	20	150 (6")	150-150	35	120	1059x414x469
100SWE65-22-7.5	7.5	10	2900	108	31	100 (4")	100-100	35	118	1059x414x469
100SWE45-22-5.5	5.5	7.5	2900	100	28	100 (4")	100-100	30	93	954x404x437
100SWE100-15-7.5/4	7.5	10	1450	140	21	100 (4")	100-100	55	150	1154x549x532
100SWE65-15-5.5/4	5.5	7.5	1450	120	18	100 (4")	100-100	55	145	1154x549x532
80SWE30-36-7.5	7.5	10	2900	75	41	80 (3")	80-80	30	118	1059x414x469
80SWE30-30-5.5	5.5	7.5	2900	70	35	80 (3")	80-80	30	93	954x404x437
80SWE45-22-7.5/4	7.5	10	1450	80	26	80 (3")	80-80	30	150	1127x550x450
50SWE20-45-7.5	7.5	10	2900	45	50	50 (2")	50-50	20	120	1032x430x360

**Materials Table**

No.	Part	Material
1	Cable	
2	Cable holder	HT200
3	Upper cover	HT200
4	Upper bearing seat	HT200
5	Frame	HT200
6	Stator	
7	Rotor	
8	Bearing	
9	Oil chamber	HT200
10	*Detector	
11	Mechanical seal	Silicon/Carbon
12	Mechanical seal	Silicon/Silicon
13	Release valve	
14	Pump casing	HT200
15	Impeller	HT200
16	Baseplate	HT200
17	Pump body	HT200
18	* Floating switch	
19	* Thermal sensor	
20	Bearing	
21	Ring	06Cr19Ni10
22	*Signal cable	

Standard configuration not equipped with detector, floating switch, thermal sensor and signal cable, available on request.

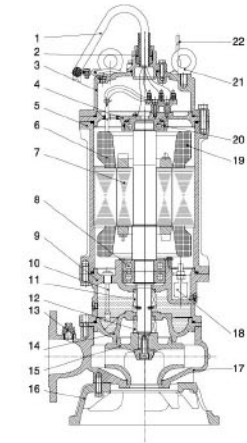

**Hydraulic Performance Curves**

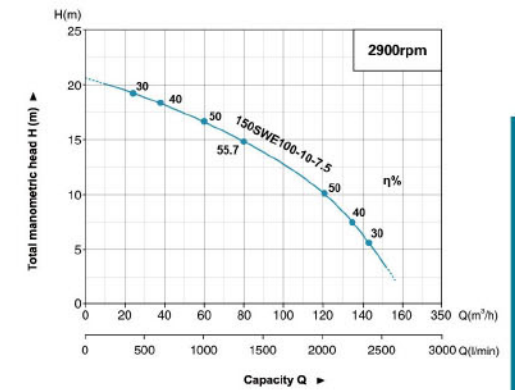
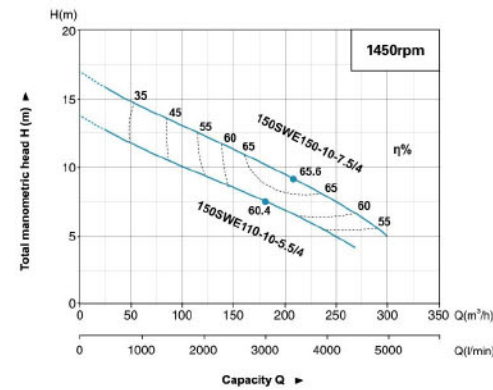

### Hydraulic Performance Curves

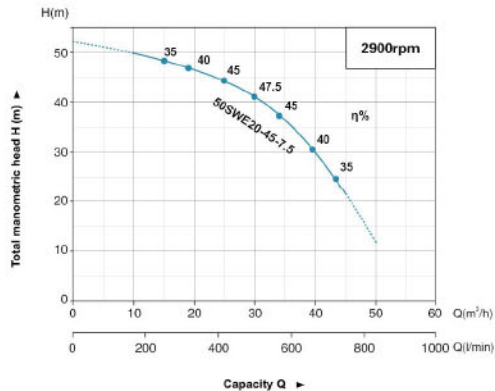
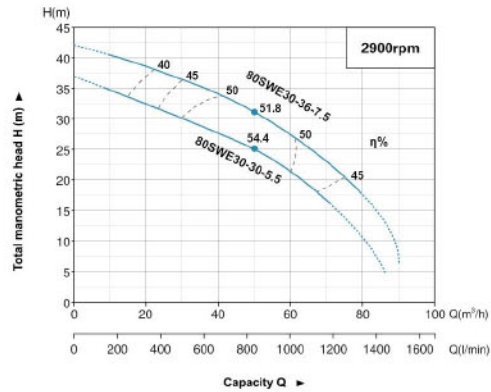
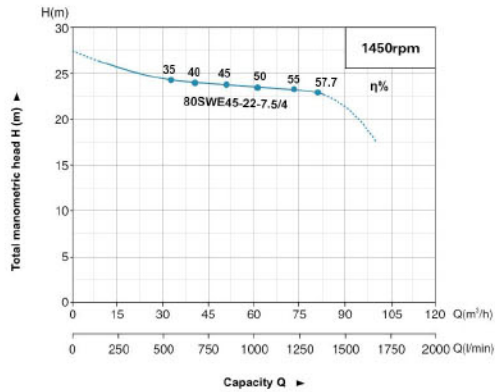
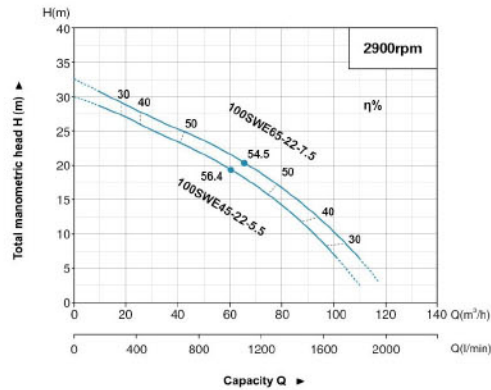
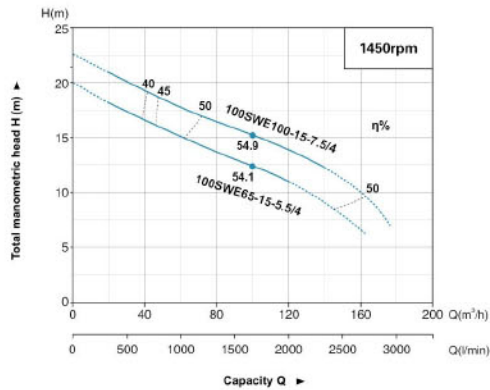

### Dimension

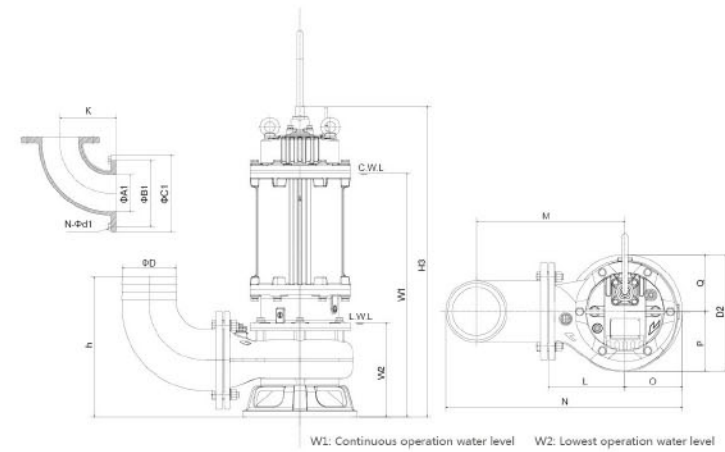

Model	Φ D	Φ A1	Φ B1	Φ C1	N-Φd1	h	W1	W2	H3	K	N	O	P	Q	L	M	D2
150SWE150-10-7.5/4	150	150	225	265	8-Φ18	465	756	330	910	230	770	195	217	170	300	500	387
150SWE110-10-5.5/4	150	150	225	265	8-Φ18	465	756	330	910	230	770	195	217	170	300	500	388
150SWE100-10-7.5	150	150	225	265	8-Φ18	379	660	241	811	230	640	145	162	155	210	410	317
100SWE65-22-7.5	100	100	170	210	4-Φ18	315	639	220	790	150	530	155	155	155	200	340	310
100SWE45-22-5.5	100	100	170	210	4-Φ18	315	609	220	744	150	530	155	155	155	200	340	310
100SWE100-15-7.5/4	100	100	170	210	4-Φ18	390	722	295	873	150	655	187	200	175	280	420	373
100SWE65-15-5.5/4	100	100	170	210	4-Φ18	390	722	295	873	150	655	187	200	175	280	420	373
80SWE30-36-7.5	80	80	150	190	4-Φ18	332	640	215	785	140	520	143	155	155	200	335	310
80SWE30-30-5.5	80	80	150	190	4-Φ18	332	607	215	735	140	515	136	155	155	200	335	310
80SWE45-22-7.5/4	80	80	150	190	4-Φ18	390	679	285	880	155	615	173	179	260	395	349	390
50SWE20-45-7.5	50	50	110	140	4-Φ14	284	626	221	777	105	484	133	137.5	200	320	272	284



## Guide Rail System

- Suitable for pumps with flange conforming ISO7005-92 standard.
- Automatic engagement with flanged elbow

## Includes

- Duck-foot bend
- Guide hook
- Flange connector
- Upper guide support
- Bolts and lock washers  
(Foundation bolts and guide pipes are not included)

## Identification Codes

**SW 50 - 50**

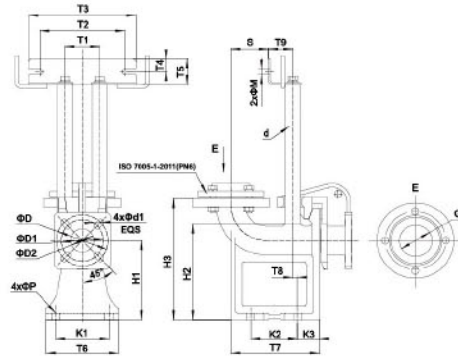
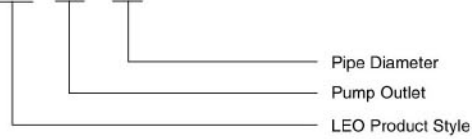

## Dimension

Model	D	D1	D2	T1	T2	T3	T4	T5	T6	T7	T8	T9	K1	K2	K3	H1	H2	H3	S	M	P	d	d1	G
SW50-50(PN6)	110	90	50	75	182	230	28	55	165	190	12	52.5	115	100	45	170	205	260	80.5	12	18	25	14	G2
SW65-65(PN6)	130	-	65	85	182	230	28	55	190	210	17	59	145	120	45	175	220	270	89	12	18	32	14	G2.5
SW80-80(PN6)	160	-	80	85	182	230	28	55	220	242	27	59	175	180	41	190	248	290	115	12	18	32	18	G3

## Package Information: Carton ( Wooden Case Optional )

Model	Carton				Wooden Case			
	L (mm)	W (mm)	H (mm)	G.W (kg)	L (mm)	W (mm)	H (mm)	G.W (kg)
SW50-50(PN6)	390	345	260	18.5	410	355	250	23
SW65-65(PN6)	430	375	285	24	440	375	275	28
SW80-80(PN6)	475	410	310	32.5	485	405	305	36

## Flange Elbow



## Dimension

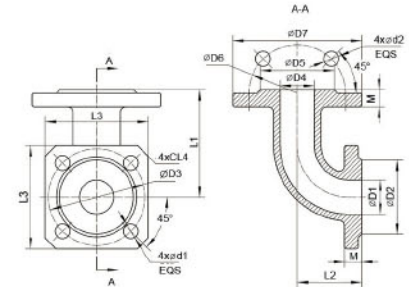

Model	D1	D2	D3	D4	D5	D6	D7	L1	L2	L3	L4	M	d1	d2
32-32 Flange Elbow	32	69	90	32	69	90	120	100	80	96	10	16	14	14
40-50 Flange Elbow	40	78	100	50	88	110	140	120	80	110	15	16	14	14
50-50 Flange Elbow	50	88	110	50	88	110	140	105	105	120	15	16	14	14
65-65 Flange Elbow	65	108	130	65	108	130	160	130	130	145	20	16	14	14
80-80 Flange Elbow	80	124	150	80	124	160	190	155	155	145	15	18	18	18

## Hose Coupling



## Dimension

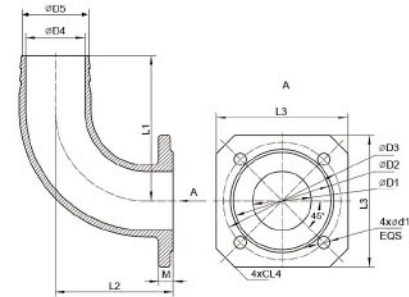

Model	D1	D2	D3	D4	D5	L1	L2	L3	L4	M	d1
• 50-40 Hose Coupling	50	88	110	38	48	115	85	120	15	16	14
• 65-50 Hose Coupling	65	108	130	51	61	125	88	145	20	16	14
• 80-80 Hose Coupling	80	124	150	60	70	140	75	145	15	16	18
50-50 Hose Coupling	50	88	110	50	58	140	120	120	15	16	14
65-65 Hose Coupling	65	108	130	65	74	160	130	145	20	18	14
80-80 Hose Coupling	80	124	150	80	87	190	135	145	15	18	18

• Product standard



### Application

- Wastewater drainage in factories, construction sites and commercial facilities
- Drainage system in municipal sewage treatment plants
- Drainage station in residential quarters
- Municipal projects
- Methane pools and field irrigation in countryside

### Pump

- Max. immersion depth: 10m ( 0.75-5.5kW-2P ), 20m ( 7.5kW-2P/5.5-45kW-4P )
- Cable length: 8 m
- Max. liquid temperature: up to +40°C
- Liquid PH value: 6 - 10
- Max. liquid density: 1.3x10<sup>3</sup>kg/m<sup>3</sup>
- Allowed by the particle diameter: 20 - 80 mm
- Float switch: single phase

### Motor

- Copper winding
- Insulation class: B ( 0.75-5.5kW-2P ), F ( 7.5kW-2P/5.5-45kW-4P )
- Protection class: IPX8
- Motor protection: built in ( 0.75-7.5kW-2P, 5.5-7.5kW-4P )

### Identification Codes

#### 65 WQ D 15-10-1.1(F)

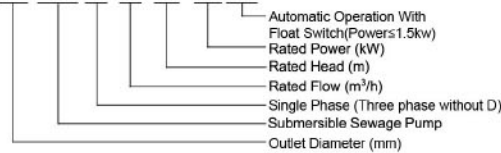

### Technical Data

Model	Motor Power	Speed	Max. Flow	Max. Head	Motor Power	Discharge	Guide Rail	Max. Solid Dia	N.W	G.W	Packing Dimension	
	V	r.p.m	m <sup>3</sup> /h	m	kW	HP	in					Fitting
50WQ10-10-0.75	380	2850	26	12	0.75	1	2	50-50	25	18.5	20	490x255x240
50WQD10-10-0.75(F)	220	2850	26	12	0.75	1	2	50-50	25	19.5	21	490x255x240
50WQ8-16-1.1	380	2850	29	18	1.1	1.5	2	50-50	20	24	25.5	490x255x240
50WQD8-16-1.1(F)	220	2850	29	18	1.1	1.5	2	50-50	20	25.5	27	490x255x240
65WQ15-10-1.1	380	2850	33	15	1.1	1.5	2 1/2	50-50	25	23	24.5	490x255x240
65WQD15-10-1.1(F)	220	2850	33	15	1.1	1.5	2 1/2	50-50	25	23.5	25	490x255x240
50WQ8-20-1.5	380	2850	25	22	1.5	2	2	50-50	20	25	25	520x260x240
50WQD8-20-1.5(F)	220	2850	25	22	1.5	2	2	50-50	20	26	28	520x260x240
65WQ15-15-1.5	380	2850	37	20	1.5	2	2 1/2	50-50	25	26.5	28	510x255x240
65WQD15-15-1.5(F)	220	2850	37	20	1.5	2	2 1/2	50-50	25	26.5	28	510x255x240
50WQ15-20-2.2	380	2850	40	22	2.2	3	2	50-50	20	44	48	690x260x315
65WQ25-17-2.2	380	2850	42	22	2.2	3	2 1/2	65-65	20	42	46	690x260x315
80WQ40-9-2.2	380	2850	64	16	2.2	3	3	80-80	30	46	51.5	710x260x315
50WQ15-26-3	380	2850	46	28	3	4	2	50-50	20	49	54	710x260x315
60WQ25-22-3	380	2850	62	26	3	4	2 1/2	65-65	20	52	57	710x260x315
80WQ40-13-3	380	2850	75	20	3	4	3	80-80	30	54	60	750x240x325
100WQ60-9-3	380	2850	92	19	3	4	4	100-100	30	57	63	750x240x325
65WQ25-28-4	380	2850	58	33	4	5.5	2 1/2	65-65	20	61	69	780x260x325
80WQ40-18-4	380	2850	81	24	4	5.5	3	80-80	30	64	71.2	800x260x325
100WQ60-13-4	380	2850	93	24	4	5.5	4	100-100	30	65	73	800x260x325
50WQ15-40-5.5	380	2850	52	42	5.5	7.5	2	50-50	20	73	81	790x290x355
80WQ30-30-5.5	380	2850	47	36	5.5	7.5	3	80-80	30	73	83	800x290x335
100WQ65-15-5.5	380	2850	110	25	5.5	7.5	4	100-100	30	79	89	810x300x375
50WQ20-45-7.5	380	2850	37	52	7.5	10	2	50-50	25	114	127.5	934x364x435

Model	Motor Power	Speed	Max. Flow	Max. Head	Motor Power	Discharge	Guide Rail	Max. Solid Dia	N.W	G.W	Packing dimension	
	V	r.p.m	m <sup>3</sup> /h	m	kW	HP	in					Fitting
80WQ30-35-7.5	380	2850	80	40	7.5	10	3	80-80	30	112	126	934x364x435
100WQ65-22-7.5	380	2850	110	34	7.5	10	4	100-100	35	115	129.5	964x384x435
150WQ100-10-7.5	380	2850	160	20	7.5	10	6	150-150	35	115	130	1014x384x455
100WQ65-15-5.5(4P)	380	1450	150	19	5.5	7.5	4	100-100	50	142	158	905x415x555
150WQ110-10-5.5(4P)	380	1450	200	26	5.5	7.5	6	150-150	55	151	167.5	935x445x585
100WQ100-15-7.5(4P)	380	1450	170	24	7.5	10	4	100-100	50	158	176	955x415x555
150WQ150-10-7.5(4P)	380	1450	240	16	7.5	10	6	150-150	75	169	186	985x445x585
200WQ250-6-7.5(4P)	380	1450	400	12	7.5	10	8	200-200	75	200	218	730x490x1115
100WQ100-22-11(4P)	380	1450	190	31	11	15	4	100-100	50	253	271	700x470x1100
150WQ150-15-11(4P)	380	1450	260	24	11	15	6	150-150	60	256	274	700x470x1130
200WQ300-9-11(4P)	380	1450	450	17	11	15	8	200-200	70	280	298	700x500x1170
100WQ100-27-15(4P)	380	1450	210	35	15	20	4	100-100	50	275	293	700x470x1150
150WQ150-20-15(4P)	380	1450	290	29	15	20	6	150-150	60	277	295	700x470x1170
200WQ300-12-15(4P)	380	1450	490	21	15	20	8	200-200	70	302	320	700x500x1220
100WQ100-31-18.5(4P)	380	1450	200	38	18.5	25	4	100-100	50	326	344.5	700x460x1240
150WQ150-24-18.5(4P)	380	1450	300	32	18.5	25	6	150-150	60	327	346	700x460x1240
200WQ300-15-18.5(4P)	380	1450	530	25	18.5	25	8	200-200	70	354	373	720x510x1280
100WQ100-36-22(4P)	380	1450	220	44	22	30	4	100-100	50	348	366.5	700x480x1240
150WQ150-28-22(4P)	380	1450	330	39	22	30	6	150-150	60	347	367	700x480x1240
200WQ300-18-22(4P)	380	1450	550	27	22	30	8	200-200	70	374	395	720x510x1280
250WQ500-11-22(4P)	380	1450	800	22	22	30	10	250-250	85	390	411	720x600x1350
150WQ150-34-30(4P)	380	1450	310	45	30	40	6	150-150	55	497	519	780x600x1430
200WQ300-21-30(4P)	380	1450	570	33	30	40	8	200-200	80	519	541	820x620x1470
250WQ500-14-30(4P)	380	1450	860	27	30	40	10	250-250	85	512	535	780x660x1490
300WQ800-8-30(4P)	380	1450	1040	22	30	40	12	300-300	90	557	581	860x720x1540
150WQ150-40-37(4P)	380	1450	330	50	37	50	6	150-150	55	557	579	780x600x1480
200WQ300-25-37(4P)	380	1450	620	39	37	50	8	200-200	80	576	598	820x620x1520
250WQ500-18-37(4P)	380	1450	930	30	37	50	10	250-250	85	570	593	780x650x1540
300WQ800-11-37(4P)	380	1450	1060	25	37	50	12	300-300	90	614	638	860x720x1590
200WQ300-30-45(4P)	380	1450	860	43	45	60	8	200-200	80	612	634	820x620x1520
250WQ500-21-45(4P)	380	1450	950	34	45	60	10	250-250	85	606	629	780x650x1540
300WQ800-14-45(4P)	380	1450	1080	28	45	60	12	300-300	90	650	674	860x720x1590

### Materials Table

Item No.	Part Name	Material
01	Handle	Steel
02	Upper cover	Cast iron
03	Capacitor	
04	Thermal protector	
05	Upper bearing seat	Cast iron
06	Bearing	
07	Stator	
08	Rotor	
09	Bearing	
10	Motor body	Cast iron
11	Bearing seat	Cast iron
12	Pump body	Cast iron
13	Impeller	Cast iron
14	Base	Cast iron
15	Cable	
16	Mechanical seal	SiC/SiC/Carbon Ceramic (<7.5 kW) SiC/SiC/SiC (>7.5 kW)
17	Oil seal	
18	Hose coupling	Cast iron
19	Terminal box	Cast iron
20	Seal bracket	Cast iron
21	Wiring terminal	

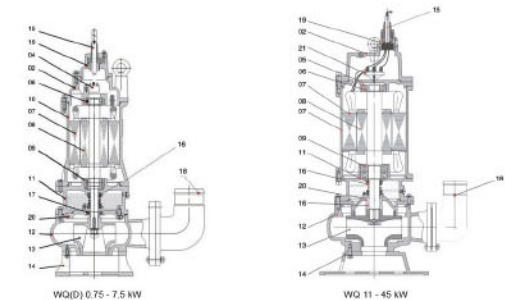

### Hydraulic Performance Curves

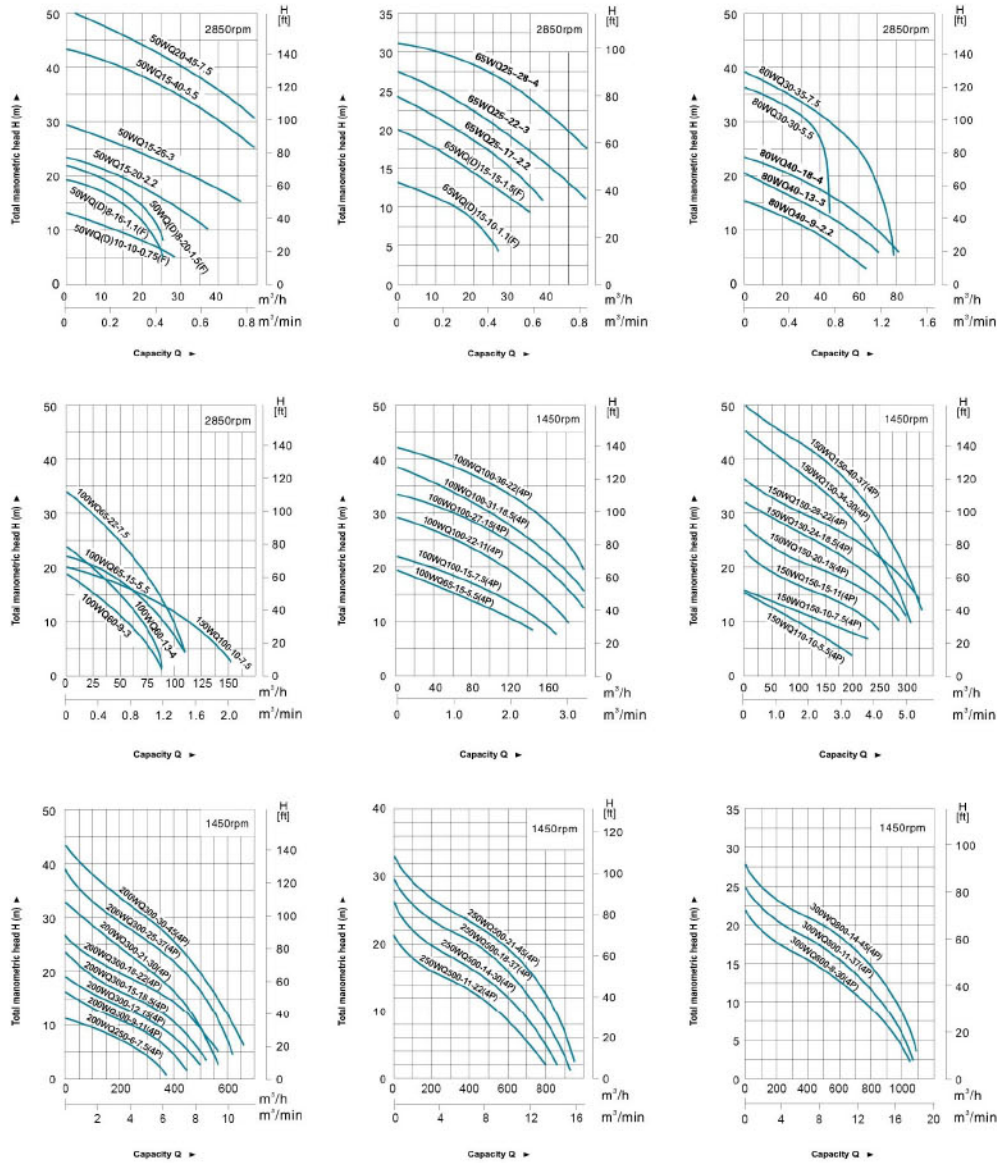

### Dimension

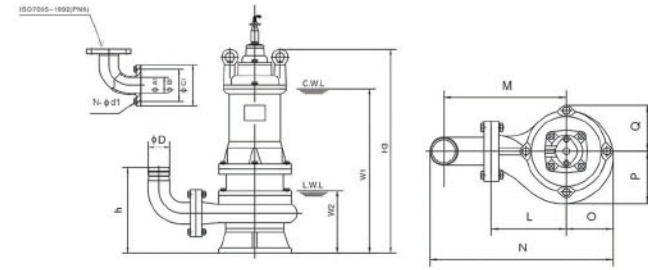

Model	ΦD	ΦA1	ΦB1	ΦC1	n-Φd1	h	W1	W2	H3	N	O	P	Q	L	M
50WQ10-10-0.75	50	50	110	140	4-Φ14	200	300	120	445	332	90	96	86	128	192
50WQD10-10-0.75(F)	50	50	110	140	4-Φ14	200	315	120	445	332	90	96	85	128	192
50WQ8-16-1.1	50	50	110	140	4-Φ14	195	325	120	460	347	90	96	85	128	192
50WQD8-16-1.1(F)	50	50	110	140	4-Φ14	195	325	120	460	347	90	96	85	128	192
65WQ15-10-1.1	65	50	110	140	4-Φ14	195	345	120	460	347	90	96	85	128	192
65WQD15-10-1.1(F)	65	50	110	140	4-Φ14	195	345	120	460	347	90	96	85	128	192
50WQ8-20-1.5	50	50	110	140	4-Φ14	202	370	165	480	340	90	105	82	145	210
50WQD8-20-1.5(F)	50	50	110	140	4-Φ14	202	390	165	500	340	90	105	82	145	210
65WQ15-15-1.5	65	50	110	140	4-Φ14	195	345	120	480	347	90	96	85	128	192
65WQD15-15-1.5(F)	65	50	110	140	4-Φ14	195	345	120	480	347	90	96	85	128	192
50WQ15-20-2.2	50	50	110	140	4-Φ14	210	410	145	575	357	107	113	100	164	228
65WQ25-17-2.2	65	65	130	160	4-Φ14	225	410	145	575	383	107	113	100	164	234
80WQ40-9-2.2	80	65	150	190	4-Φ14	255	415	150	580	392	105	111	93	160	250
50WQ15-26-3	50	50	110	140	4-Φ14	210	425	145	610	357	107	113	100	164	228
65WQ25-22-3	65	65	130	160	4-Φ14	225	425	145	610	383	107	113	100	164	234
80WQ40-13-3	80	80	150	190	4-Φ18	270	450	170	630	387	107	115	100	153	243
100WQ60-9-3	100	80	170	210	4-Φ18	295	450	170	630	410	107	115	100	153	253
65WQ25-28-4	65	65	130	160	4-Φ14	240	455	160	650	409	111	116	106	179	249
80WQ40-18-4	80	80	150	190	4-Φ18	280	480	185	675	407	105	110	100	165	255
100WQ60-13-4	100	80	170	210	4-Φ18	305	480	185	675	430	105	110	100	165	265
50WQ15-40-C.5	50	50	110	140	4-Φ14	235	475	100	675	360	125	130	112	175	259
80WQ30-30-5.5	80	80	150	190	4-Φ18	275	495	175	690	427	115	120	110	175	265
100WQ65-15-5.5	100	100	170	210	4-Φ18	285	505	190	705	462	131	140	115	181	281
50WQ20-45-7.5	50	50	110	140	4-Φ12	265	540	210	4760	449	140	146	134	200	264
80WQ30-35-7.5	80	80	150	190	4-Φ18	305	540	210	760	490	140	146	134	200	290
100WQ65-22-7.5	100	100	170	210	4-Φ18	345	560	230	780	513	145	154	135	200	300
150WQ100-10-7.5	150	150	225	265	8-Φ18	405	575	245	795	598	145	160	135	210	360

**Dimension**

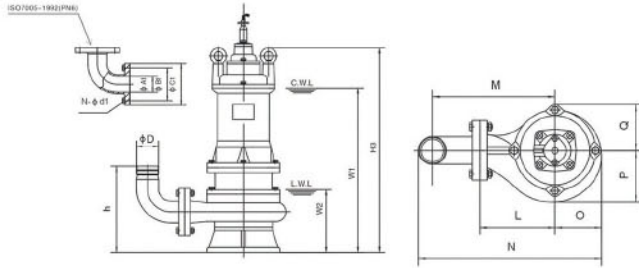

Model	ΦD	ΦA1	ΦB1	ΦC1	n-Φd1	h	W1	W2	H3	N	O	P	Q	L	M
100WQ65-15-5.5(4P)	100	100	170	210	4-Φ18	360	585	255	805	620	190	202	177	280	380
150WQ110-10-5.5(4P)	150	150	225	265	8-Φ18	430	615	285	835	725	200	215	185	300	450
100WQ100-15-7.5(4P)	100	100	170	210	4-Φ18	360	630	255	850	620	190	202	177	280	380
150WQ150-10-7.5(4P)	150	150	225	265	8-Φ18	430	660	285	880	725	200	215	185	300	450
200WQ250-6-7.5(4P)	200	200	295	340	8-Φ22	540	695	320	915	880	230	256	192	350	550
100WQ100-22-11(4P)	100	100	170	210	4-Φ18	355	650	255	910	671	206	217	193	310	410
150WQ150-15-11(4P)	150	150	225	265	8-Φ18	440	680	285	940	756	208	225	188	320	470
200WQ300-9-11(4P)	200	200	295	340	8-Φ22	545	720	325	980	866	226	253	191	340	540
100WQ100-27-15(4P)	100	100	170	210	4-Φ18	355	695	255	955	671	206	217	193	310	410
150WQ150-20-15(4P)	150	150	225	265	8-Φ18	440	725	285	985	756	208	225	188	320	470
200WQ300-12-15(4P)	200	200	295	340	8-Φ22	545	765	325	1025	866	226	253	191	340	540
100WQ100-31-18.5(4P)	100	100	170	210	4-Φ18	355	715	185	1010	693	218	227	206	325	425
150WQ150-24-18.5(4P)	150	150	225	265	8-Φ18	415	740	290	1035	781	221	235	206	335	485
200WQ300-16-18.5(4P)	200	200	295	340	8-Φ22	545	785	330	1080	883	233	260	203	350	550
100WQ100-36-22(4P)	100	100	170	210	4-Φ18	355	735	265	1030	693	218	227	206	325	425
150WQ150-28-22(4P)	150	150	225	265	8-Φ18	415	760	290	1055	781	221	235	206	335	485
200WQ300-18-22(4P)	200	200	295	340	8-Φ22	545	805	330	1100	883	233	260	203	350	550
250WQ500-11-22(4P)	250	250	350	395	12-Φ22	635	860	400	1160	1150	280	313	270	400	673
150WQ150-34-30(4P)	150	150	240	285	8-Φ22	475	855	340	1200	997	272	283	270	380	582
200WQ300-21-30(4P)	200	200	295	340	8-Φ22	580	895	380	1240	1078	286	308	270	390	622
250WQ500-14-30(4P)	250	250	350	395	12-Φ22	-	920	400	1265	1181	300	332	270	410	683
300WQ800-8-30(4P)	300	300	400	445	12-Φ22	-	970	450	1315	1365	340	366	290	480	803
150WQ150-40-37(4P)	150	150	240	285	8-Φ22	463	850	340	1255	997	272	283	270	380	582
200WQ300-25-37(4P)	200	200	295	340	8-Φ22	593	890	380	1295	1078	286	308	270	390	622
250WQ500-18-37(4P)	250	250	350	395	12-Φ22	665	910	400	1315	1181	300	332	270	410	683
300WQ800-11-37(4P)	300	300	400	445	12-Φ22	750	860	450	1365	1365	340	366	290	480	803
200WQ300-30-45(4P)	200	200	295	340	8-Φ22	560	930	380	1295	1078	286	308	270	390	622
250WQ500-21-45(4P)	250	250	350	395	12-Φ22	665	950	400	1315	1181	300	332	270	410	683
300WQ800-14-45(4P)	300	300	400	445	12-Φ22	750	1000	450	1365	1365	340	366	290	480	803

**Guide Rail System**

- Suitable for pumps with flange conforming ISO7005-92 standard.
- Automatic engagement with flanged elbow

**Includes**

- Duck-foot bend
  - Guide hook
  - Flange connector
  - Upper guide support
  - Bolts and lock washers
- (Foundation bolts and guide pipes are not included)

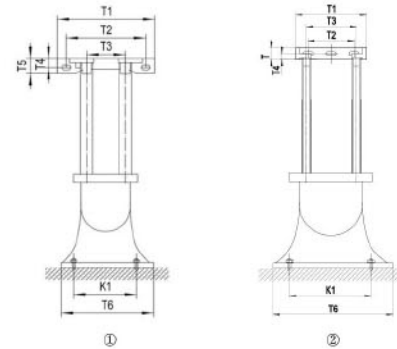

① . T2 > T3, Model 50-50(PN6) to 100-100(PN6)  
② . T2 < T3, Model 150-150(PN6) to 300-300(PN10)

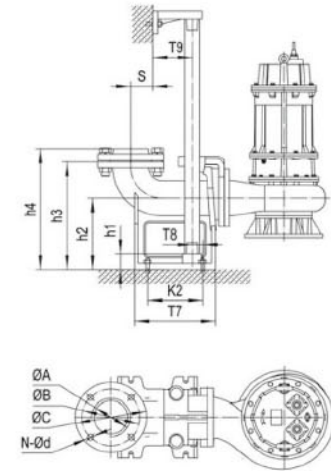

Model	ΦA	ΦB	ΦC	N-Φd	T1	T2	T3	T4	T5	T6	T7	T8	T9	K1	K2	S	h1	h2	h3	h4	I	II	III
50-50(PN6)	Φ50/G2"	110	140	4-Φ14	265	215	105	25	42	200	215	15	67	165	135	63	25	160	250	280	1"Φ33.3x3.5	4-M16x120	2-M12x40
65-65(PN6)	Φ65/G2 1/2"	130	160	4-Φ14	280	230	125	30	50	230	235	20	70	190	155	90	25	165	295	295	1"Φ33.3x3.5	4-M16x120	2-M12x40
80-80(PN6)	Φ80/G3"	150	190	4-Φ18	315	265	145	27	50	255	225	30	78	215	155	77	25	190	305	335	1 1/2"Φ48.3x3.5	4-M16x120	2-M12x40
100-100(PN6)	Φ100/G4"	170	210	4-Φ18	365	305	170	32	55	295	280	35	95	265	175	100	25	230	350	380	1 1/2"Φ48.3x3.5	4-M16x150	2-M12x50
150-150(PN6)	Φ150	225	265	8-Φ18	400	260	280	24	48	400	410	75	95	280	300	200	390	300	480	-	1 1/2"Φ48.3x3.5	4-M20x150	2-M14x50
150-150(PN10)	Φ150	240	280	8-Φ22	400	260	280	24	48	400	410	75	95	280	300	200	390	300	480	-	1 1/2"Φ48.3x3.5	4-M20x150	2-M14x50
200-200(PN10)	Φ200	295	340	8-Φ22	400	260	280	24	48	400	445	100	95	300	355	230	440	325	555	-	1 1/2"Φ48.3x3.5	4-M20x150	2-M14x50
250-250(PN10)	Φ250	350	395	12-Φ22	400	260	280	24	48	480	555	110	95	360	430	295	460	315	630	-	1 1/2"Φ48.3x3.5	4-M22x150	2-M14x50
300-300(PN10)	Φ300	400	445	12-Φ22	520	340	375	32	65	550	600	140	110	414	460	280	480	415	730	-	2"Φ60.3x3.5	4-M24x200	2-M14x50

I = Dimensions of tube for guide rod.  
II = Quantity and specification of foundation bolt.  
III = Quantity and specification of upper guide rod bolt.



## Application

- Used In pressure sewage system
- Drainage of wastewater from individual residences, apartn recreational developments, models
- Transferring wastewater of commercial buildings, industrial plants, wastewater sampling, small hospitals
- Schools, federal, state and local parks, wastewater drainage
- To transfer various wastewater and sewage

## Pump

- Flexible installations with hoses, pipes or quick-coupling
- Double-end mechanical seal
- Stainless Stell welded shaft
- Liquid density  $\leq 1.2 \times 10^3 \text{kg/m}^3$
- Liquid temperature: 0 - 40 °C
- Liquid PH value: 4 - 10
- Max. immersion Depth: 5 m

## Motor

- Copper winding
- Insulation class: F
- Ingress protection: IPX8

## Identification Codes

**50 WQ D 8-16-1.1 T(M)**

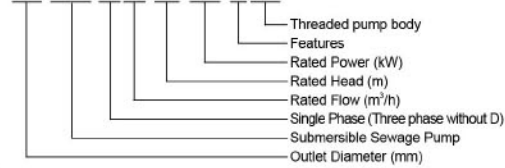

( Hose coupling as standard. Flange elbow is available on request. Float switch is available on request. )

## Materials Table

Item No.	Part Name	Material
01	Cable	
02	Handle	AISI 304
03	Top Cover	HT200
04	O-Ring	NBR
05	End Cover	HT200
06	O-Ring	NBR
07	Wave Spring Washer	55Mn
08	Bearing	
09	Rotor	
10	Stator	
11	Motor Casing	HT200
12	Bearing	
13	Oil Chamber	HT200
14	Mechanical Seal	
15	Pressing	AISI 304
16	O-Ring	NBR
17	Cylinder Head	HT200
18	Oil Seal	
19	Impeller	HT200
20	Pump Body	HT200
21	Base	HT200

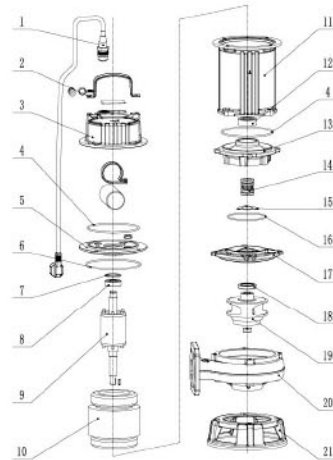

## Hydraulic Performance Curves

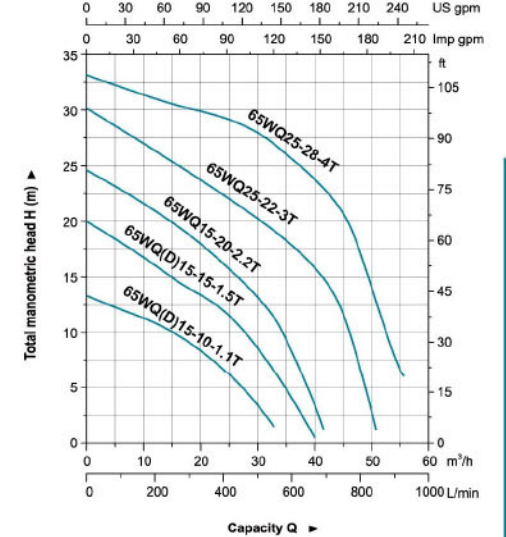
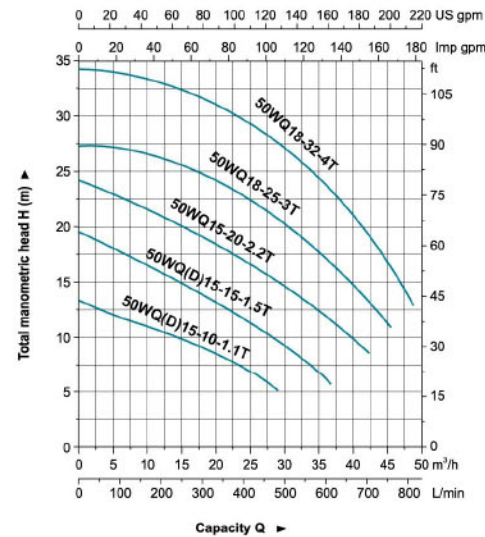
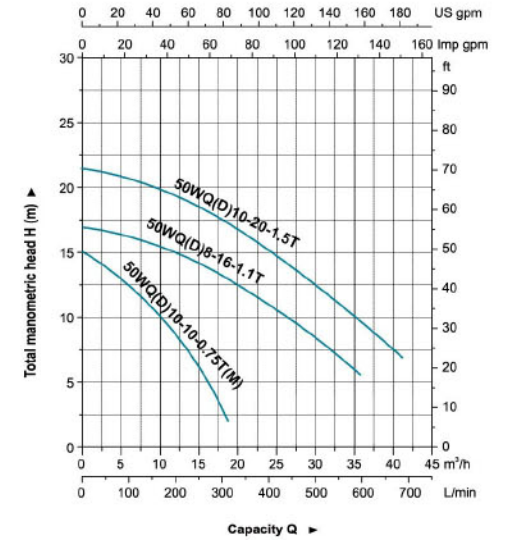
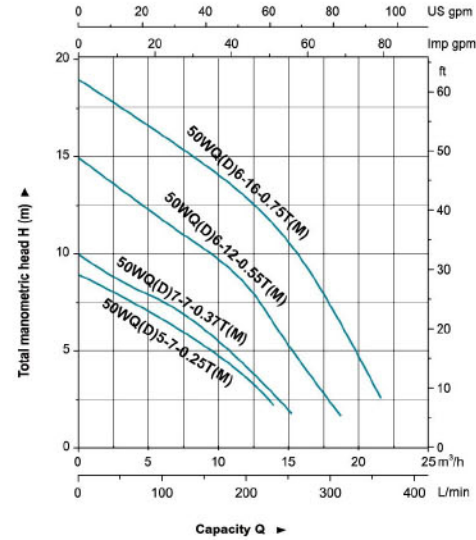

## Hydraulic Performance Curves

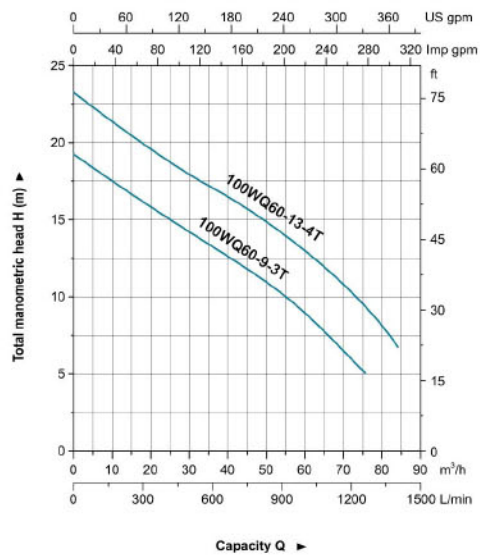
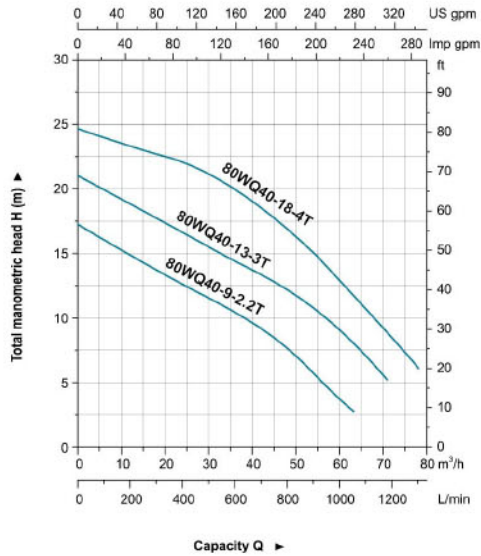

## Technical Data

Model	Voltage V	Speed rpm	Max. Flow m <sup>3</sup> /h	Max. Head m	Power kW	HP	Outlet Inch	Guide Rial Fitting	Solid Passage mm	N.W kg	G.W (Flange elbow) kg	G.W (Hose coupling) kg	G.W (Thread models) kg	Packing Dimension mm	Quantity (PCS/20' TEU)
50WQD5-7-0.25T	220	2850	14	8	0.25	0.33	2"	50-50	5	16	22.7	21.1	/	544*235*214	1000
50WQD5-7-0.25TM	220	2850	14	8	0.25	0.33	2"	50-50	5	15.9	/	/	18.8	484*269*214	1000
50WQD7-7-0.37T	220	2850	15	10	0.37	0.55	2"	50-50	15	18.1	22.8	21.2	/	544*235*214	1000
50WQD7-7-0.37TM	220	2850	15	10	0.37	0.55	2"	50-50	15	15.9	/	/	18.9	484*269*214	1000
50WQD6-12-0.55T	220	2850	19	15	0.55	0.75	2"	50-50	15	16.7	23.4	21.7	/	544*235*214	1000
50WQD6-12-0.55TM	220	2850	19	15	0.55	0.75	2"	50-50	15	16.4	/	/	19.4	484*269*214	1000
50WQD8-16-0.75T	220	2850	22	19	0.75	1	2"	50-50	15	17.7	24.4	22.7	/	544*235*214	1000
50WQD6-16-0.75TM	220	2850	22	19	0.75	1	2"	50-50	15	17.5	/	/	20.4	484*269*214	1000
50WQD10-10-0.75T	220	2850	19	15	0.75	1	2"	50-50	20	17.5	24.2	22.6	/	544*235*214	1000
50WQD10-10-0.75TM	220	2850	19	15	0.75	1	2"	50-50	20	17.3	/	/	20.3	484*269*214	1000
50WQ5-7-0.25T	380	2850	14	8	0.25	0.33	2"	50-50	5	15.3	22	20.4	/	544*235*214	1000
50WQ5-7-0.25TM	380	2850	14	8	0.25	0.33	2"	50-50	5	15.2	/	/	18.1	484*269*214	1000
50WQ7-7-0.37T	380	2850	15	10	0.37	0.55	2"	50-50	15	15.4	22.1	20.5	/	544*235*214	1000
50WQ7-7-0.37TM	380	2850	15	10	0.37	0.55	2"	50-50	15	15.3	/	/	18.3	484*269*214	1000
50WQ6-12-0.55T	380	2850	19	15	0.55	0.75	2"	50-50	15	16.5	23.2	21.5	/	544*235*214	1000
50WQ6-12-0.55TM	380	2850	19	15	0.55	0.75	2"	50-50	15	16.4	/	/	19.3	484*269*214	1000
50WQ6-16-0.75T	380	2850	22	19	0.75	1	2"	50-50	15	17.2	23.9	22.2	/	544*235*214	1000
50WQ6-16-0.75TM	380	2850	22	19	0.75	1	2"	50-50	15	16.9	/	/	19.8	484*269*214	1000
50WQ10-10-0.75T	380	2850	19	15	0.75	1	2"	50-50	20	17	23.7	22.1	/	544*235*214	1000
50WQ10-10-0.75TM	380	2850	19	15	0.75	1	2"	50-50	20	16.8	/	/	19.7	484*269*214	1000
50WQ8-16-1.1T	220	2850	36	19.4	1.1	1.5	2"	50-50	15	25.6	33	31.4	/	544*269*244	792
50WQD15-10-1.1T	220	2850	29.3	13.5	1.1	1.5	2"	50-50	25	25.2	32.6	30.9	/	544*269*244	792
50WQD10-20-1.5T	220	2850	41.3	21.6	1.5	2	2"	50-50	15	25.8	33.4	31.8	/	604*269*244	876
50WQD15-15-1.5T	220	2850	37	19.4	1.5	2	2"	50-50	25	25.7	33.3	31.7	/	604*269*244	876
50WQ8-16-1.1T	380	2850	36	19.4	1.1	1.5	2"	50-50	15	29.9	37.3	35.6	/	544*269*244	792
50WQ15-10-1.1T	380	2850	29.3	13.5	1.1	1.5	2"	50-50	25	29.5	36.9	35.3	/	544*269*244	792
50WQ10-20-1.5T	380	2850	41.3	22.4	1.5	2	2"	50-50	15	24.3	31.9	30.3	/	544*269*244	792
50WQ15-15-1.5T	380	2850	36.9	19.3	1.5	2	2"	50-50	25	24	31.6	29.9	/	544*269*244	876
50WQ15-20-2.2T	380	2850	42.5	24	2.2	3	2"	50-50	20	30.1	37.7	36	/	604*269*244	876
80WQ40-9-2.2T	380	2850	63.2	18	2.2	3	3"	80-80	25	31.2	40.4	38.7	/	604*269*244	876
50WQ18-25-3T	380	2850	45.5	27.1	3	4	2"	50-50	20	42.8	52.2	50.6	/	744*324*279	432
65WQ25-22-3T	380	2850	50	30.2	3	4	2 1/2"	65-65	25	43.4	53.7	52.1	/	744*324*279	432
80WQ40-13-3T	380	2850	70.4	20.6	3	4	3"	80-90	25	44.8	55.8	54.1	/	744*324*279	432
100WQ60-9-3T	380	2850	76	20	3	4	4"	100-100	25	46.8	61.1	59.4	/	744*324*279	432
50WQ19-32-4T	380	2850	48.7	33.5	4	5.5	2"	50-50	20	45.5	54.9	53.3	/	744*324*279	432
65WQ25-28-4T	380	2850	56.3	33.2	4	5.5	2 1/2"	65-65	25	46.1	56.4	54.8	/	744*324*279	432
80WQ40-18-4T	380	2850	78.1	24.7	4	5.5	3"	80-90	25	47.4	58.2	56.5	/	744*324*279	432
100WQ60-13-4T	380	2850	84.2	23.4	4	5.5	4"	100-100	25	49.6	63.9	62.2	/	744*324*279	432
65WQD15-10-1.1T	220	2850	31.6	12.9	1.1	1.5	2 1/2"	65-65	25	25.8	34.2	32.5	/	544*269*244	792
65WQ15-10-1.1T	380	2850	32.9	13.2	1.1	1.5	2 1/2"	65-65	25	24.6	33	31.3	/	544*269*244	792
65WQ15-15-1.5T	380	2850	39.8	20.1	1.5	2	2 1/2"	65-65	25	26.3	34.7	33	/	544*269*244	792
65WQD15-15-1.5T	220	2850	39.7	19.9	1.5	2	2 1/2"	65-65	25	30.1	38.7	37	/	604*269*244	876
65WQ15-20-2.2T	380	2850	41.6	24.6	2.2	3	2 1/2"	65-65	20	30.7	39.3	37.6	/	604*269*244	876

**Dimension**

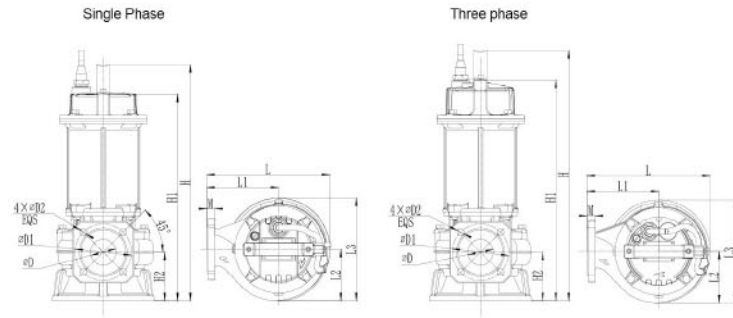

Model	L	L1	L2	L3	M	H	H1	H2	D	D1	D2
50WQD5-7-0.25T	214	120	99	187	16	422	374	81	50	110	14
50WQD7-7-0.37T	214	120	99	187	16	422	374	81	50	110	14
50WQD6-12-0.55T	214	120	99	187	16	422	374	81	50	110	14
50WQD6-16-0.75T	214	120	99	187	16	422	374	81	50	110	14
50WQD10-10-0.75T	214	120	99	187	16	422	374	81	50	110	14
50WQ5-7-0.25T	214	120	99	187	16	422	374	81	50	110	14
50WQ7-7-0.37T	214	120	99	187	16	422	374	81	50	110	14
50WQ6-12-0.55T	214	120	99	187	16	422	374	81	50	110	14
50WQ6-16-0.75T	214	120	99	187	16	422	374	81	50	110	14
50WQ10-10-0.75T	214	120	99	187	16	422	374	81	50	110	14
50WQD8-16-1.1T	240	140	99	200	16	487.5	429.5	94.5	50	110	14
50WQD15-10-1.1T	240	140	99	200	16	487.5	429.5	94.5	50	110	14
50WQD10-20-1.5T	240	140	99	200	16	523	465.5	94.5	50	110	14
50WQD15-15-1.5T	240	140	99	200	16	523	465.5	94.5	50	110	14
50WQ8-16-1.1T	240	140	99	200	16	459.5	402	94.5	50	110	14
50WQ15-10-1.1T	240	140	99	200	16	459.5	402	94.5	50	110	14
50WQ10-20-1.5T	240	140	99	200	16	459.5	402	94.5	50	110	14
50WQ15-15-1.5T	240	140	99	200	16	459.5	402	94.5	50	110	14
50WQ15-20-2.2T	240	140	99	200	16	495.5	438	94.5	50	110	14
80WQ40-9-2.2T	240	140	103	203	18	515.5	458	106.5	80	150	19
50WQ18-25-3T	289	170	121.5	240	16	530	484	109.5	50	110	14
65WQ25-22-3T	289	170	121.5	240	16	530	484	109.5	65	130	14
80WQ40-13-3T	289	170	123	242	18	553	507	121.5	80	150	19
100WQ60-9-3T	303	180	135	254	18	557	511	125.5	100	170	19
50WQ18-32-4T	289	170	121.5	240	16	530	484	109.5	50	110	14
65WQ25-26-4T	289	170	121.5	240	16	530	484	109.5	65	130	14
80WQ40-18-4T	289	170	123	242	18	553	507	121.5	80	150	19
100WQ60-13-4T	303	180	135	254	18	557	511	125.5	100	170	19
65WQD15-10-1.1T	240	140	99	200	16	490	432	97	65	130	14
65WQ15-10-1.1T	240	140	99	200	16	462	404.5	97	65	130	14
65WQ15-15-1.5T	240	140	99	200	16	462	404.5	97	65	130	14
65WQD15-15-1.5T	240	140	99	200	16	526	468	97	65	130	14
65WQ15-20-2.2T	240	140	99	200	16	498	440.5	97	65	130	14

**Dimension**

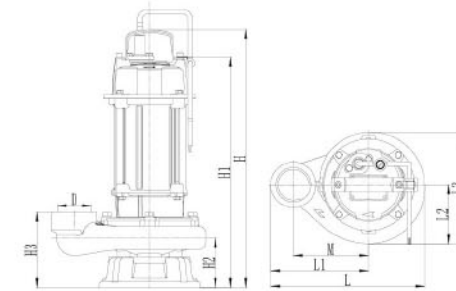

Model	L	L1	L2	L3	M	H	H1	H2	H3	D
50WQD5-7-0.25TM	252	160	97	183	123	422	374	81	123	G2
50WQD7-7-0.37TM										
50WQD6-12-0.55TM										
50WQD6-16-0.75TM										
50WQD10-10-0.75TM										
50WQ5-7-0.25TM										
50WQ7-7-0.37TM										
50WQ6-12-0.55TM										
50WQ6-16-0.75TM										
50WQ10-10-0.75TM										



### Application

- Civil engineering
- Mines, quarries, Coal ore & slurries
- Sewage treatment plants
- General pumping purposes

### Pump

- Max. liquid temperature: +40°C
- Flow: up to 156 m<sup>3</sup>/h
- Head: up to 57 m
- Power: 1.5 kW (2 HP) to 15kW (20 HP)
- Max. Immersion depth: 25 m
- Optional cable length

### Motor

- Copper winding
- Insulation class: B
- Protection class: IP68

### Identification Codes

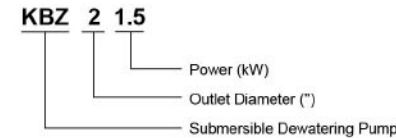

### Technical Data

Model	Discharge mm	Power		Max. Head m	Max. Flow		Max. Solid Dia mm
		kW	HP		m <sup>3</sup> /h	l/min	
KBZ21.5	50	1.5	2	22	33	550	8.5
KBZ22.2	50	2.2	3	26	33	550	8.5
KBZ23.7	50	3.7	5	34	33	550	8.5
KBZ31.5	80	1.5	2	14.5	40	670	8.5
KBZ32.2	80	2.2	3	19	55	920	8.5
KBZ33.7	80	3.7	5	29	55	920	8.5
KBZ35.5	80	5.5	7.5	34	75	1250	8.5
KBZ43.7	100	3.7	5	19.5	90	1500	8.5
KBZ45.5	100	5.5	7.5	23	105	1750	8.5

### Dimension

Model	d	A	A1	B	D	H	W1
KBZ21.5	50	235	173	517	216	486	120
KBZ31.5	80	235	173	517	216	486	120
KBZ22.2	50	235	173	517	216	486	120
KBZ32.2	80	235	173	517	216	486	120
KBZ23.7	50	283	208	628	252	638	150
KBZ33.7	80	283	208	628	252	638	150
KBZ43.7	100	283	208	642	252	638	150
KBZ35.5	80	306	218	671	259	598	150
KBZ45.5	100	306	218	686	259	598	150

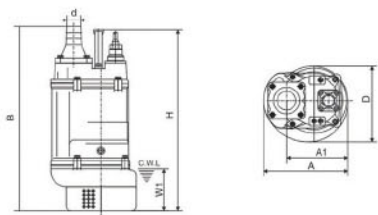

### Hydraulic Performance Curves

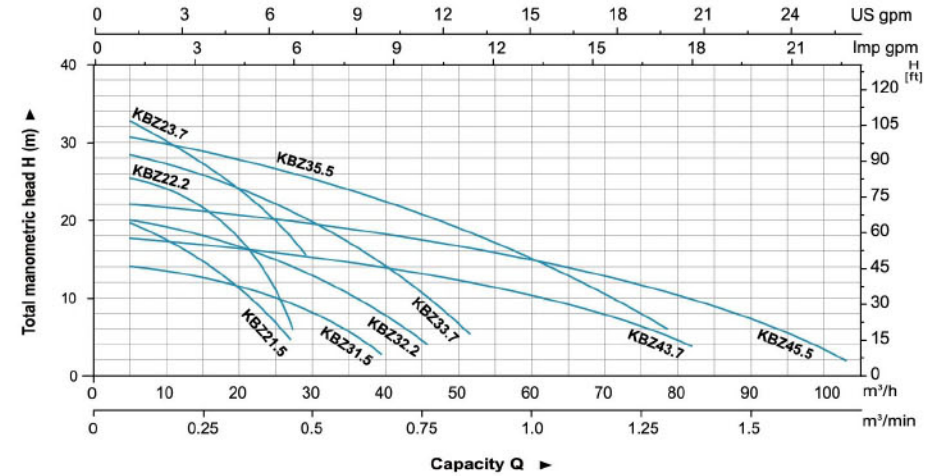

### Materials Table

No.	Part	Material	No.	Part	Material
1	Hose coupling	Cast iron	9	Cable	
2	Thermal protector		10	Bearing	
3	Upper cover	Cast iron	11	Rotor	
4	Motor cover	Cast iron	12	Stator	
5	Oil seal		13	Bearing	
6	Mechanical seal	Lower Sic-Sic Upper Carbon-Sic(≤2.2kW) Lower Sic-Sic Upper Sic-Sic(≥3.7kW)	14	Impeller	High chrome alloy
7	Strainer	Steel	15	Pump body	Cast iron
8	Handle	Steel	16	Inlet plate	Ductile iron

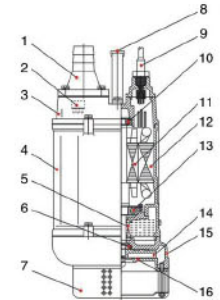

### Package Information

Model	N.W (kg)	G.W (kg)	L (mm)	W (mm)	H (mm)	Quantity (PCS/20 TEU)
KBZ21.5	34.5	37.5	585	270	270	648
KBZ22.2	36	39	585	270	270	648
KBZ23.7	60	65	685	325	300	408
KBZ31.5	34.5	37	585	270	270	648
KBZ32.2	36	39	585	270	270	648
KBZ33.7	60	65	685	325	300	408
KBZ35.5	77	84	725	355	370	288
KBZ43.7	61	66	685	325	300	408
KBZ45.5	78	85	725	355	370	288

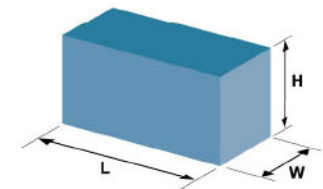



### Application

- Civil engineering
- Mines, quarries, Coal ore & slurries
- Sewage treatment plants
- General pumping purposes

### Pump

- Max. liquid temperature: +40°C
- Flow: up to 156 m<sup>3</sup>/h
- Head: up to 57 m
- Power: 1.5 kW (2 HP) to 15kW (20 HP)
- Max. Immersion depth: 25 m
- Optional cable length

### Motor

- Copper winding
- Insulation class: B
- Protection class: IP68

### Identification Codes

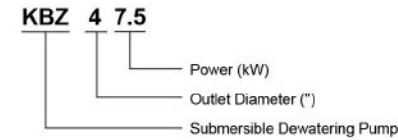

### Technical Data

Model	Discharge mm	Power		Max. Head m	Max. Flow		Max. Solid Dia mm
		kW	HP		m <sup>3</sup> /h	l/min	
KBZ47.5	100	7.5	10	40	84	1400	11.5
KBZ411	100	11	15	48.5	84	1400	11.5
KBZ415	100	15	20	56	84	1400	11.5
KBZ67.5	150	7.5	10	31	124.8	2080	19.5
KBZ611	150	11	15	32	147	2450	19.5
KBZ615	150	15	20	40	166	2600	19.5

### Dimension

Model	d	A	A1	B	D	H	WT
KBZ47.5	100	330	240	764	314	676	190
KBZ411	100	373	255	807	350	695	190
KBZ67.5	150	330	240	790	314	676	190
KBZ611	150	373	255	807	350	695	190
KBZ415	100	373	255	842	350	755	190
KBZ615	150	373	255	842	350	755	190

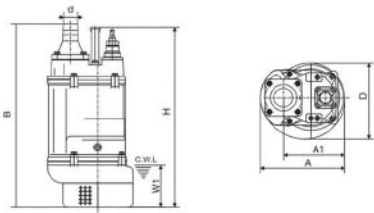

### Hydraulic Performance Curves

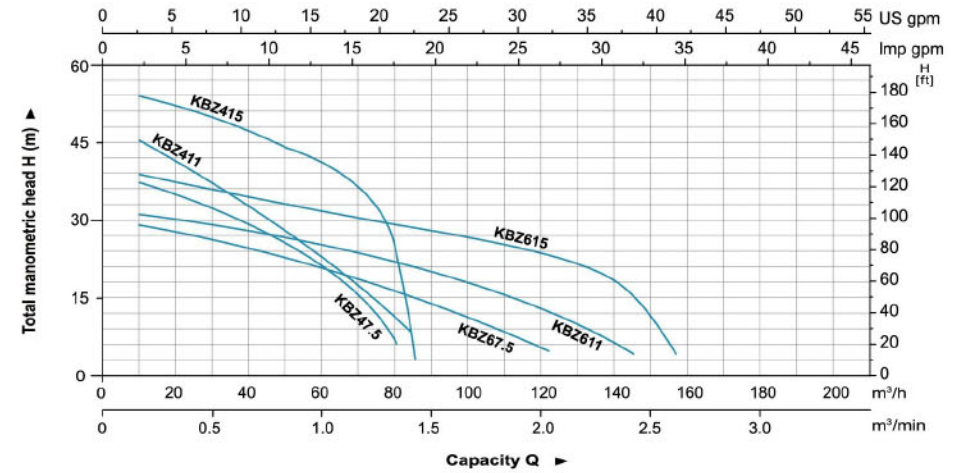

### Materials Table

No.	Part	Material	No.	Part	Material
1	Hose coupling	Cast iron	9	Cable	
2	Thermal protector		10	Bearing	
3	Upper cover	Cast iron	11	Rotor	
4	Motor cover	Cast iron	12	Stator	
5	Oil seal		13	Bearing	
6	Mechanical seal	Lower: SiC-SiC Upper: Carbon-SiC(52.2kW) Lower: SiC-SiC Upper: SiC-SiC(23.7kW)	14	Impeller	High chrome alloy
7	Strainer	Steel	15	Pump body	Cast iron
8	Handle	Steel	16	Inlet plate	Ductile iron

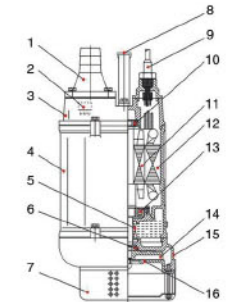

### Package Information

Model	N.W (kg)	G.W (kg)	L (mm)	W (mm)	H (mm)	Quantity (PCS/20 TEU)
KBZ47.5	105	114	805	365	390	215
KBZ411	130	140	895	415	440	160
KBZ415	142	153	895	415	440	160
KBZ67.5	106	114	835	365	390	205
KBZ611	133	143	855	415	440	160
KBZ615	145	156	895	415	440	160

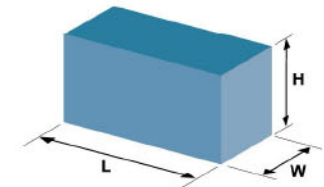



### Application

- Civil engineering
- Mines, quarries, Coal ore & slurries
- Sewage treatment plants
- General pumping purposes
- Pumping fluid: sludge, liquids containing mud and bentonite

### Pump

- Max. liquid temperature: +40°C
- Flow: up to 60 m<sup>3</sup>/h
- Head: up to 57 m
- Power: 1.5 kW (2 HP) to 15 kW (20 HP)
- Max. Immersion depth: 25 m
- Optional cable length

### Motor

- Copper winding
- Insulation class: B
- Protection class: IP68

### Identification Codes

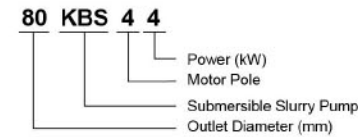

### Technical Data

Model	Discharge mm	Power		Max. Head m	Max. Flow		Max. Solid Dia mm
		kW	HP		m <sup>3</sup> /h	l/min	
80KBS44	80	4	5.5	14.8	99	1650	30
100KBS46	100	6	8	16.9	144	2400	30
150KBS49	150	9	12	21.5	192	3200	30

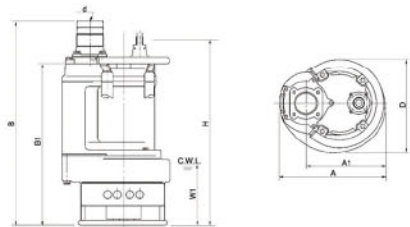

### Dimension

Model	d	A	A1	B	B1	D	H	W1
80KBS44	80	360	260	816	666	326	730	250
100KBS46	100	415	305	844	688	373	730	250
150KBS49	150	434	324	889	709	407	776	250

### Hydraulic Performance Curves

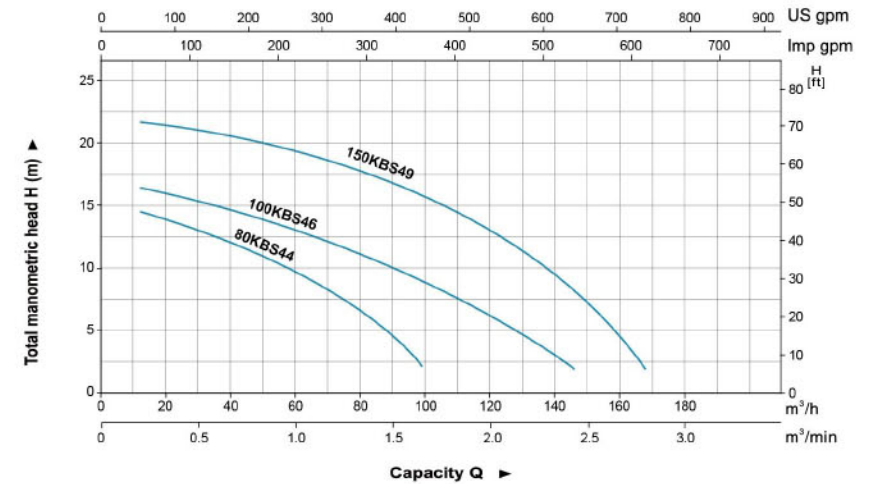

### Materials Table

No.	Part	Material	No.	Part	Material
1	Hose coupling	Cast iron	11	Stator	
2	Handle	Steel	12	Bearing	
3	Upper cover	Cast iron	13	Bearing house	Cast iron
4	Motor protector		14	Mechanical seal	Sic-Sic/Sic-Sic
5	Motor body	Cast iron	15	Oil seal	
6	Pump body	Cast iron	16	Impeller	High chrome alloy
7	Strainer	Steel	17	Inlet plate	High chrome alloy
8	Cable		18	Inlet base	Cast iron
9	Bearing		19	Agitator	High chrome alloy
10	Rotor				

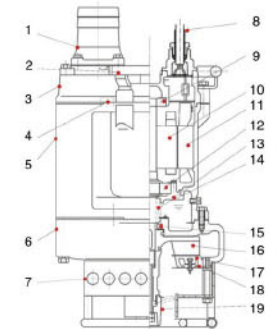

### Package Information

Model	N.W (kg)	G.W (kg)	L (mm)	W (mm)	H (mm)	Quantity (PCS/20 TEU)
80KBS44	105	113	855	415	400	190
100KBS46	145	156	415	475	990	143
150KBS49	170	184	475	475	1050	118

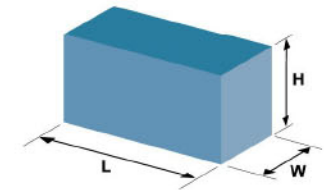



## Control Box

- The device is specially designed for automatic water drainage in pump stations, elevator shafts, sewage pits, etc.

## Features

- Liquid level control
- Excellent anti-interference performance
- The primary pump and standby pumps can be set arbitrarily. In case the primary pump is failed or water output is less than input, the standby pump(s) start to run automatically
- Display of Power and Operating status
- Manual and automatic operation mode for selection
- Protection of earth leakage, overcurrent, overvoltage, overheating and phase loss
- Audible and visual alarm

## Operating Conditions

- Ambient temperature: 5 ~ 40°C
- Humidity: ≤90%
- Operating voltage: 380 V ± 10%
- Ambient environment: Freedom from corrosive gases and/or conductive dust.

## Instructions

- DOL (Direct On Line): High starting current. Applicable for pumps with power up to 15 kW.
- Autotransformer Starter: Small starting current. Applicable for pumps with power more than 15 kW.
- Soft Starter: Smooth starting current with small influence on the grid. Applicable for pumps with power more than 15 kW.

## Identification Codes

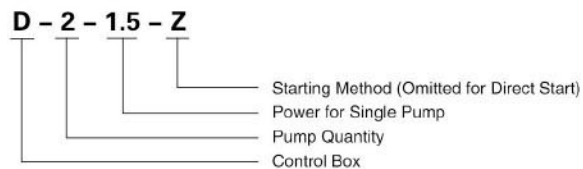

	Q	Z	R
Starting Method	Direct on Line	Autotransformer Starter	Soft Starter
Controlled Quantity	1	2	3
Control Mode	For One Pump	For Three Pumps	For Four Pumps

## Contact us:

SyncroFlo, Inc. is represented by our Group company  
**Kirloskar Brothers (Thailand) Limited for the Asia market**

ask@kirloskar.co.th

www.kirloskarthailand.com

+66 2 661 8272-4

+66 2 026 3585